

K60 NC



ANOTRONIC LTD.™

Unit 3, Hollingdon Depot, Stewkley Road, Soulbury,
Nr. Leighton Buzzard, Beds., LU7 0DF. England.
Telephone +44 (01525) 270261 Fax +44 (01525) 270235
E-Mail sales@anotronic.com
Internet <http://www.anotronic.com>



INDEX

CHAPTER 1 : SPECIFICATION

- 1-1 MACHINE BODY
- 1-2 POWER SUPPLY UNIT
- 1-3 DIELECTRIC TANK
- 1-4 STANDARD ACCESSORIES
- 1-5 SPECIAL ACCESSORIES

CHAPTER 2 : INSTALLATION SITE

- 2-1 CHOOSING THE SITE
- 2-2 DIAGRAM OF MACHINE
- 2-3 SERVICES REQUIRED
- 2-4 LEVEL ADJUSTMENT
- 2-5 DEGREASING

CHAPTER 3 : INSTALLATION

- 3-1 DIELECTRIC TANK
- 3-2 CONNECTION BETWEEN THE MACHINE AND POWER SUPPLY UNIT.

CHAPTER 4 : INSPECTION PROCEDURE OF DIELECTRIC SYSTEM

CHAPTER 5 : DIELECTRIC CIRCULATION

CHAPTER 6 : MACHINE OPERATION

- 6-1 SETTING UP THE ELECTRODE
- 6-2 CLAMPING THE WORKPIECE ON THE TABLE
- 6-3 FIXING THE WORKPIECE SQUARE
- 6-4 CLOSING THE WORK TANK DOOR
- 6-5 WORK TANK

CHAPTER 1 : SPECIFICATION

1-1 MACHINE BODY

SPECIFICATION	K60
WORK TANK DIMENSION	1090x580x360mm
TABLE DIMENSION	660x380mm
X-TRAVEL & SETTING ACCURACY	400mm
Y-TRAVEL & SETTING ACCURACY	250mm
Z-TRAVEL & SETTING ACCURACY	200mm
BACKSLIDE TRAVEL & SETTING ACCURACY	190mm
MAXIMUM TABLE - QUILL DISTANCE	600mm
MAXIMUM ELECTRODE WEIGHT	120kgs
MAXIMUM TABLE LOADING	800kgs

1-2 POWER SUPPLY UNIT

SPECIFICATION	K30A	K45A	K60A
NOMINAL CURRENT	30A	45A	60A
CONNECTED RATING	4KVA	5.5KVA	7KVA
INPUT VOLTAGE	220/380/415/440	220/380/415/440	220/380/415/440
MAXIMUM STOCK REMOVAL RATE	200mm ³ /min	300mm ³ /min	400mm ³ /min
BEST SURFACE ROUGHNESS	Ra 0.2 µm	Ra 0.2 µm	Ra 0.2 µm
BEST ELECTRODE WEARING RATE	< 0.2%	< 0.2%	< 0.2%

REMARK: THE MACHINE CAN ALSO BE SUPPLIED WITH A 90A OR 120A POWER SUPPLY UNIT.

1-3 DIELECTRIC TANK

SPECIFICATION	K60
CAPACITY	400 litre
FILTERS	3pcs

1-4 STANDARD ACCESSORIES (AS FIG. 1-1)

1. WORK CLAMP SET 1. UNIT
2. MAGNETIC FLUSHING SET 1. UNIT
3. ELECTRODE HOLDER 1. UNIT
4. SURFACE FINISH SCALE 1. UNIT

1-5 SPECIAL ACCESSORIES

1. 3R CHUCK
2. ITS CHUCK
3. PERMANENT MAGNETIC CHUCK
4. DIELECTRIC COOLER

1-1

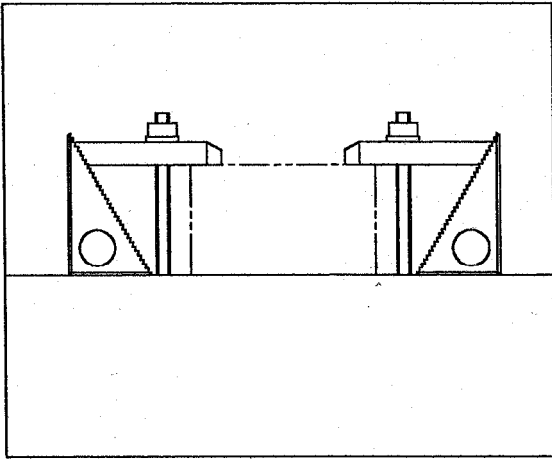

1

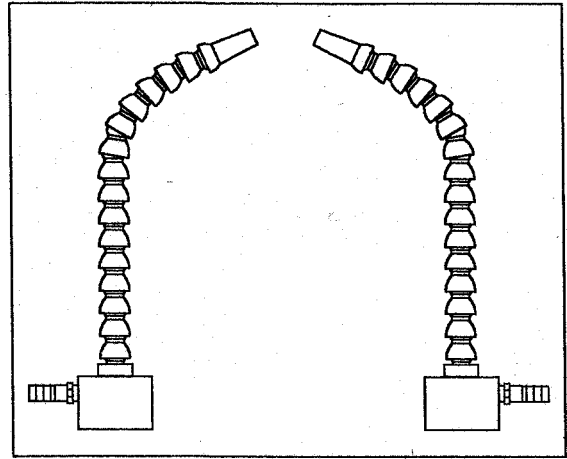

2

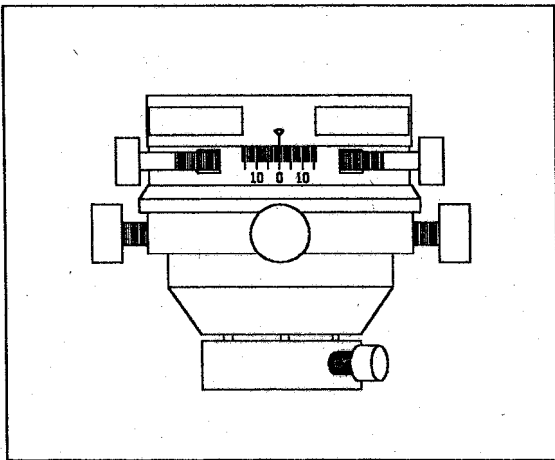

3

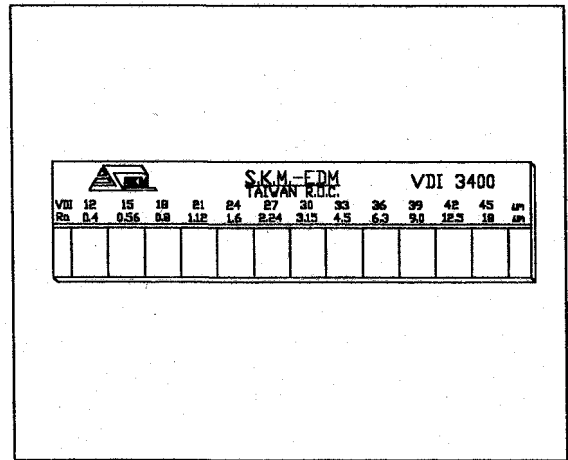

4

CHAPTER 2 : INSTALLATION SITE

2-1 CHOOSING THE SITE

1. THIS MACHINE IS A HIGH PRECISION UNIT, IT MUST BE INSTALLED IN AIRY AND CLEAN ROOM.
2. THE MACHINE MUST BE PROTECTED FROM DIRECT SUNLIGHT OR HEAT FORM RADIATORS.
3. THE SPACE AROUND THE MACHINE SHOULD BE LARGE ENOUGH FOR THE OPERATOR TO REMOVE THE COVER FOR MAINTENANCE OF THE MACHINE, AND TO OPEN/CLOSE THE MACHINE DOOR.

2-2 DIAGRAM OF MACHINE

FIG. 2-1 THE DIAGRAM ON THE RIGHT ILLUSTRATES THE AREA REQUIRED FOR INSTALLATION.

2-3 SERVICES REQUIRED

1. POWER REQUIREMENTS

AC ELECTRICAL CURRENT (POWER SUPPLY) MUST BE SUPPLIED BY BUYER, AND THE MACHINE SHOULD BE CONNECTED WITH MACHINE THROUGH A SAFETY AC BREAKER .

THE INPUT VOLTAGE ARE AC 220/380/415V 3 PHASE

MODEL K30A : POWER SUPPLY UNIT 3 PHASE 4 KVA

MODEL K45A : POWER SUPPLY UNIT 3 PHASE 5.5 KVA

MODEL K60A : POWER SUPPLY UNIT 3 PHASE 7 KVA

2. FOR SAFE OPERATION ,THE MACHINE MUST BE GROUNDED AND THE OPERATOR SHOULD STAND ON A THICK WOODEN PLATFORM.
3. ENSURE THAT THE OPERATION SITE IS WELL LIT AND VENTILATED. A STABLE TEMPERATURE IS BETTER UNDER 28°C (AIR CONDITIONER IS NECESSARY).

K60

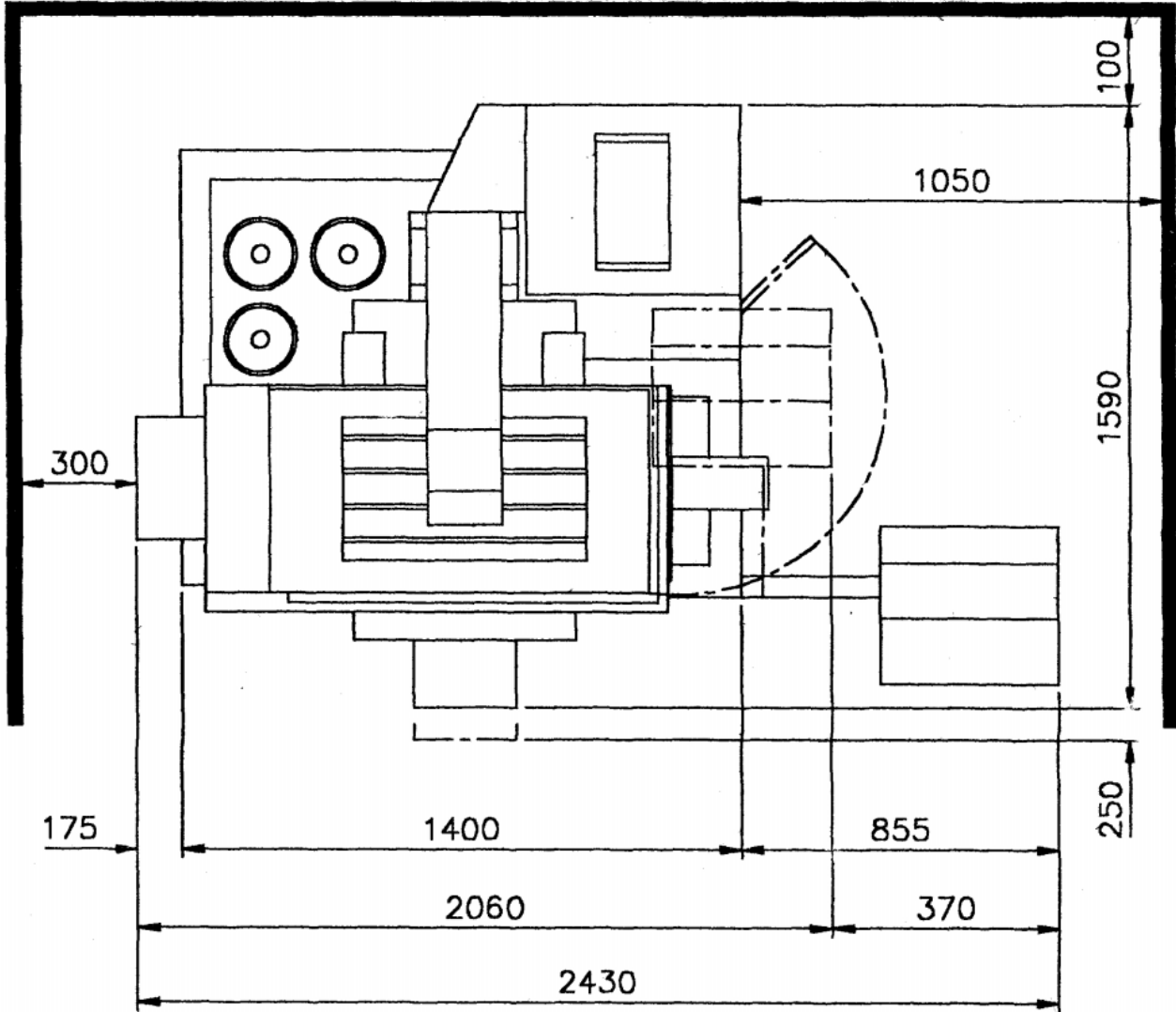

FIG. 2-1

2-4 LEVEL ADJUSTMENT

THIS MACHINE IS SUPPORTED BY FOUR FEET THAT WHEN TURNED BY WRENCH (SIZE 26) (FIG. A) CONTROL THE HORIZONTAL ADJUSTMENT. ADJUSTING THE MACHINE TO A 1 PERCENT DECLINE TO THE LEFT REAR WILL AID THE CIRCULATION OF THE FLUID.

2-5 DEGREASING

IN ORDER TO PROTECT MACHINE PARTS AND FINISHED SURFACES FROM RUSTING, THEY ARE COVERED WITH OIL PRIOR TO SHIPMENT. BEFORE OPERATING, THE MACHINE MUST BE DEGREASED. KEROSENE, GASOLINE OR FUEL OIL CAN ALL SERVE AS DEGREASING AGENTS.

ALL SLIDING OR OTHER MOVABLE PARTS MUST BE THOROUGHLY DEGREASED AND THEN CORRECTLY LUBRICATED.

THE FOLLOWING OILS ARE RECOMMENDED, THOUGH OTHERS OF EQUIVALENT PROPERTIES MAY BE USED.

SHELL TONNA OIL 68

GULF 59

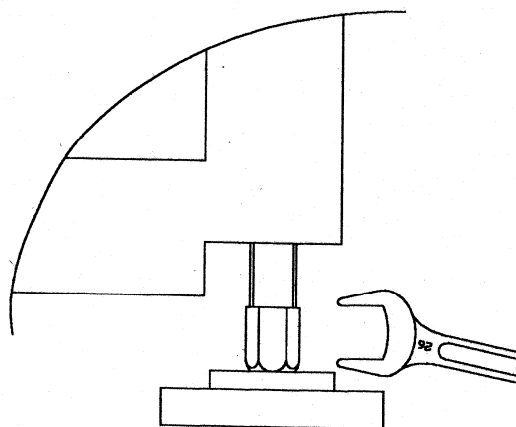

FIG. A

CHAPTER 3 : INSTALLATION

3-1 : DIELECTRIC TANK

1. FILL THE DIELECTRIC TANK FROM DRAIN BOX OR WORK TANK.
2. CAPACITY :

MODEL K60 : 400 LITERS / 88 IMPERIAL GALLONS / 104 US GALLONS

3. THE FOLLOWING DIELECTRIC FLUIDS ARE RECOMMENDED, ALTHOUGH OTHERS EQUIVALENTS MAY BE USED. (TABLE . A)

Product	Use		Viscosity (20/ 68)	Density (20/ 68)	Flash point (:)	Aromatic contents (%)
	Max. removal	Min. wear				
AGIP Lamium 14	●	●	3.32	0.77	109/228.2	0.5
ARALUX MF	●	●	3.6	0.79	125/257	0
ESSO DE-FLUID 38	●	●	3.27	0.76	117/242.6	0.01
ESSO DE-FLUID	●	●	7.37	0.82	124/255.2	0.65
BP 200T	●	●	2.9	0.76	104/219.2	0
BP 250	●	●	6	0.81	125/257	2

YOU CAN USE OTHER SIMILAR DIELECTRIC OILS BESIDES THOSE IN THE ABOVE RECOMMENDATION LIST, BUT THE FLASH POINT MUST BE OVER 70° C

TABLE . A

FIG. 3-1

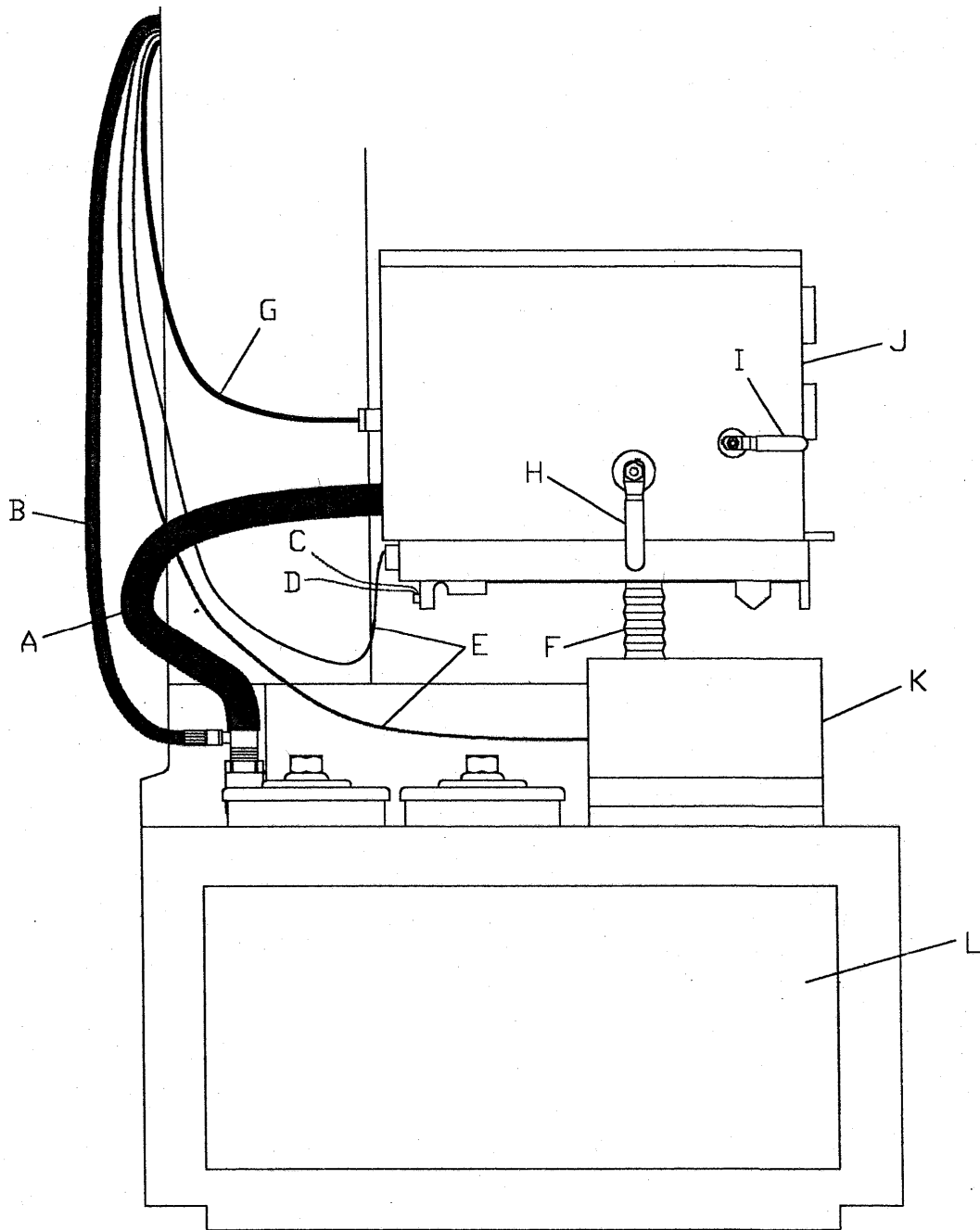

- | | |
|-------------------------|----------------------------|
| A: OIL FEED PIPE | H: TANK FILL VALVE |
| B: Z-AXIS OIL FEED PIPE | I: PRESSURE / VACUUM VALVE |
| C: EARTH CABLE | J: THE WORK TANK |
| D: NEGATIVE POWER CABLE | K: DRAIN BOX |
| E: LINEAR SCALE CABLE | L: DIELECTRIC TANK |
| F: DRAIN TUBE | |

G: OIL LEVEL, TEMPERATURE AND FLUSHING, FIRE PROTECTION & LIGHT CONTROL CABLE

3-2 CONNECTION BETWEEN THE MACHINE AND POWER SUPPLY UNIT

5 PIN ROUND 3 PHASE MAINS CONNECTOR.

L1 : RED PHASE

L2 : YELLOW PHASE

L3 : BLUE PHASE

EARTH : GREEN/YELLOW EARTH

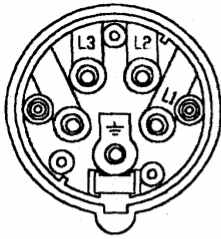

A-A'

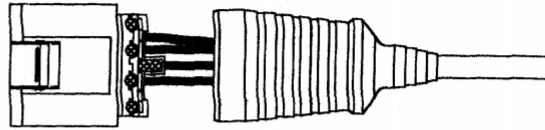

B DETAIL

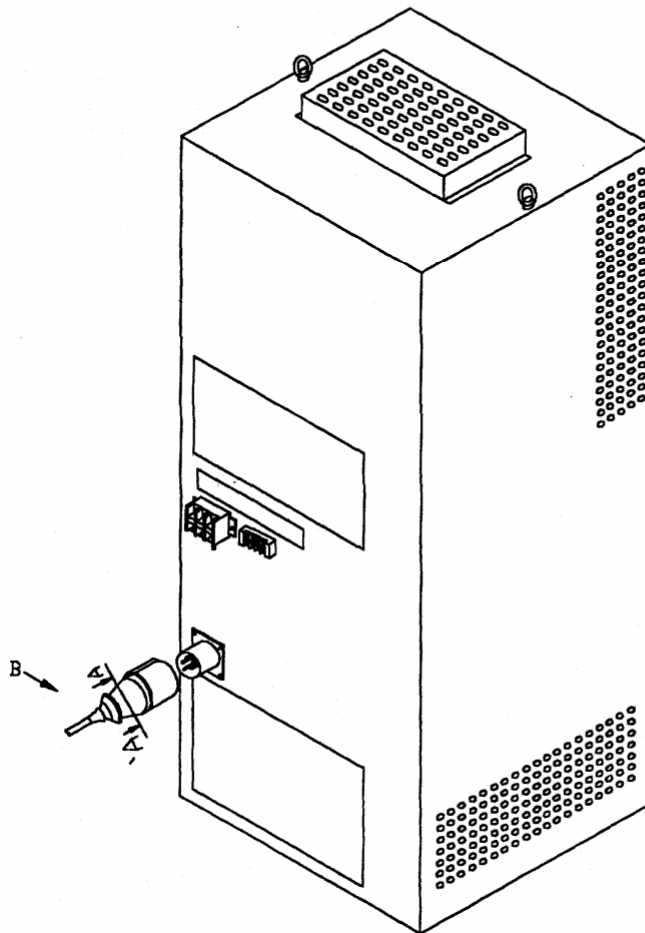

CHAPTER 4: INSPECTION PROCEDURE OF DIELECTRIC SYSTEM

PROCEDURE

1. CLOSE WORK TANK DOOR AND LOCK IT. (FIG.4-1)
2. TURN OFF 4 FLUSHING VALVES D1-D4 (REFER TO SPECIFICATION LABEL)
3. TURN RIGHT THE DRAIN GATE CONTROL ROD (FIG.4-1-E) AND IT WILL OPEN THE DRAIN GATE. (TURN C.W.)
- ※ PULL UP DRAIN GATE CONTROL ROD AND TURN LEFT TO LOCK IN POSITION (TURN C.C.W.).
4. PULL UP OIL LEVEL CONTROL ROD TO THE MAXIMUM POSITION.
- ※ THE OIL LEVEL CAN BE ADJUSTED BY THE POSITION OF OIL LEVEL CONTROL ROD (FIG.4-1-F).
5. CLOSE THE QUILL FLUSHING VALVE (TURN C.C.W.) (FIG. 4-2-G)
6. TURN THE TANK FILL VALVE TO THE HORIZONTAL “OFF” POSITION (FIG. 4-3-H).
7. TURN ON THE POWER SUPPLY ISOLATOR SWITCH (FIG. 4-4-I) AND PRESS PUMP START BUTTON ON THE CONTROL PANEL TO START THE DIELECTRIC PUMP.

THE ITEM OF INSPECTION

1. DIELECTRIC FLUID PUMP : CHECK THE DIRECTION OF ROTATION AGAINST THE “ARROW “ ON THE PUMP.
- ※ IF THE DIRECTION IS WRONG, TURN OFF THE MAIN SWITCH, CHANGE TWO OF THE POSITIONS OF INPUT 3 PHASE ELECTRIC WIRES. (THIS SHOULD ONLY BE CARRIED OUT BY A QUALIFIED ELECTRICIAN)
2. OPEN THE FLUSHING VALVES-D1 AND D2 SLIGHTLY, AND THE QUILL FLUSHING VALVE TO CONFIRM THAT THEY WORK NORMALLY.
- ※ DO NOT OPEN TOO MUCH, OTHERWISE, IT WILL SPLASH TO BECAUSE OF THE LARGE OIL PRESSURE.
3. OPEN D4 SLIGHTLY, AND MAKE SURE THAT THE DRAINING VALVE (FIG. 4-3-J) FLUSHING FUNCTION IS WORKING WHEN IT IS AT THE HORIZONTAL POSITION -“ON” .

4. OPEN D3 -THE SYNCHRONOUS FLUSHING VALVE, AND PRESS THE SYNCHRONOUS FLUSHING CONTROL “ON” SWITCH OF CONTROL PANEL, THE FLUSHING ACTION WILL BE IN ACCORD WITH THE UP-DOWN MOVEMENT OF Z-AXIS .
5. TURN THE TANK FILL VALVE (FIG. 4-3-H) TO HORIZONTAL “ON” POSITION , AND PRESS THE DIELECTRIC FLUID CONTROL “ON” SWITCH , CHECK THAT THE WORK TANK FILLS TO THE INDICATED LEVEL?

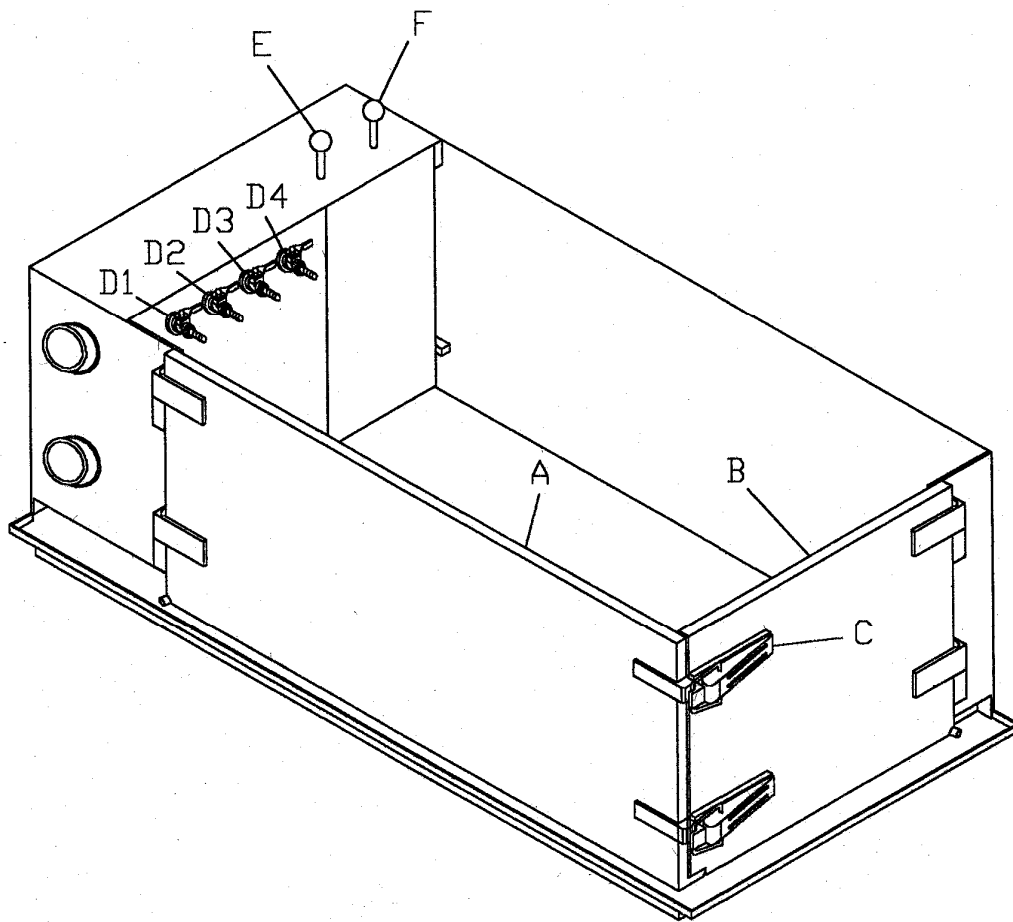

FIG. 4-1

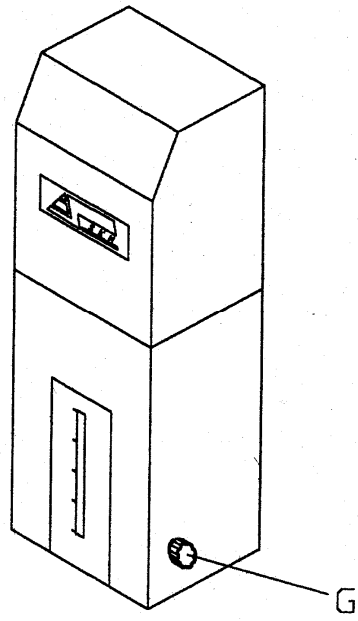

FIG. 4-2

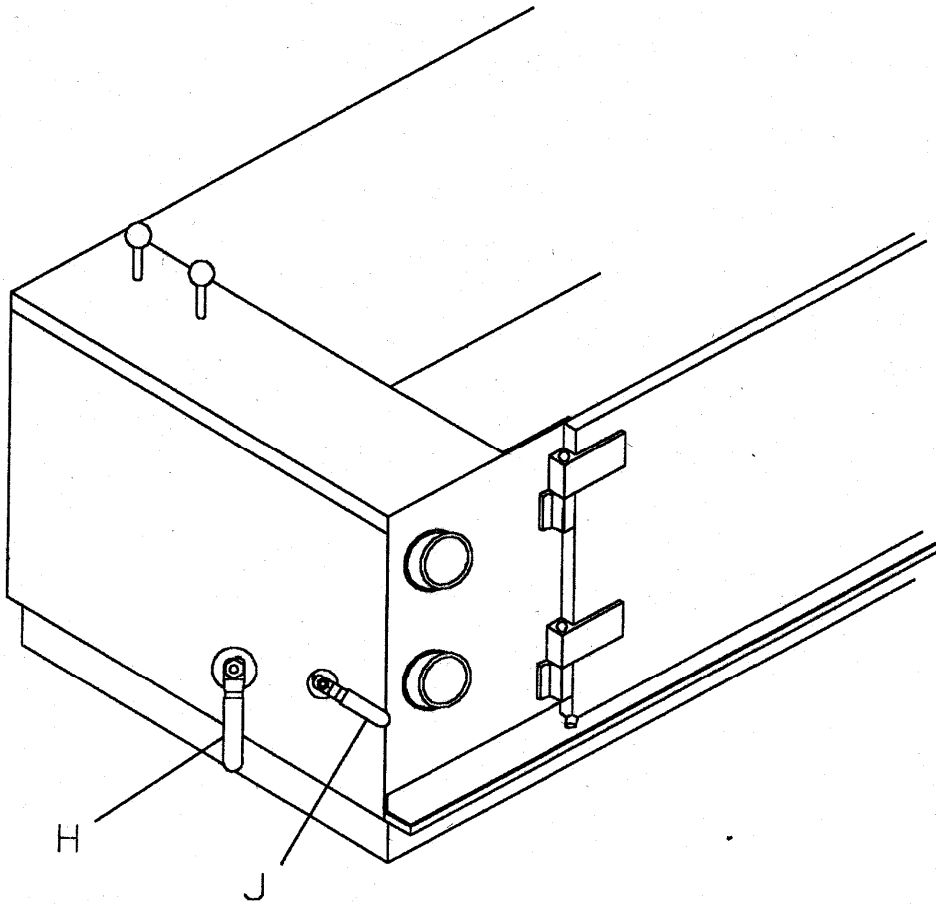

FIG. 4-3

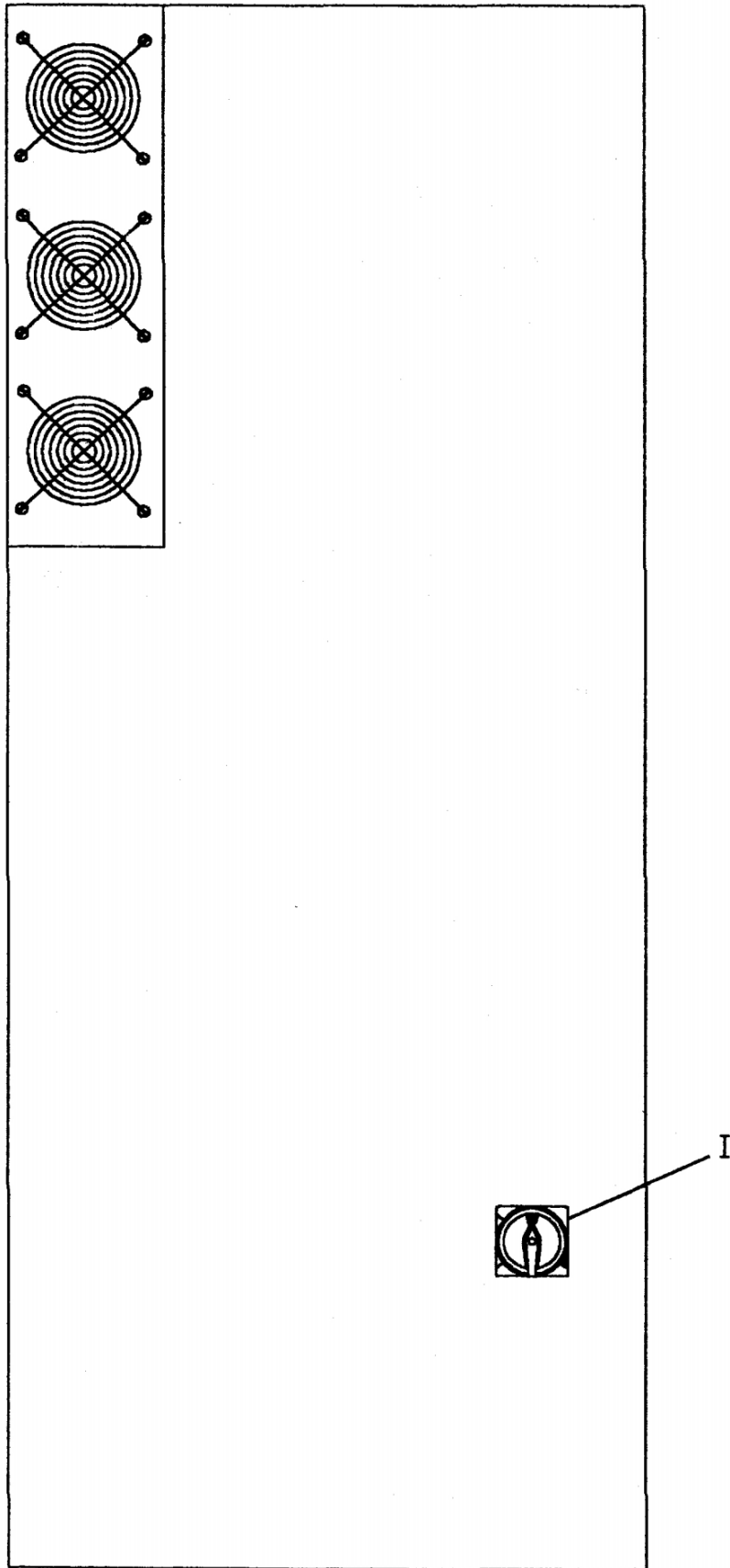

FIG. 4-4

CHAPTER 5: DIELECTRIC CIRCULATION

01- TANK FILL VALVE

02- CONTINUOUS FLUSHING VALVE

03- CONTINUOUS FLUSHING VALVE

04- SYNCHRONOUS FLUSHING VALVE

05- FLUSHING & SUCTION VALVE

06- VENTURI

07- SUCTION VALVE

08- VACUUM PRESSURE GAUGE

09- MAGNETIC CONTROL VALVE

10- PRESSURE GAUGE (PRESSURE \sim (0.8~1.5KG/CM²))

11- DRAIN GATE

12- THERMOMETER

13- OVERFLOW CONTROL

14- LIQUID LEVEL FLOAT SWITCH (FOR OVERFLOW SAFETY PROTECTION)

15- DUAL FILTER SYSTEM

16- CIRCULATION PUMP

17- WORK TANK

18- DIELECTRIC TANK

19- WORK TANK DOOR SAFETY LOCK

20- LIQUID LEVEL FLOAT SWITCH (FOR SAFETY PROTECTION OF DIELECTRIC TANK)

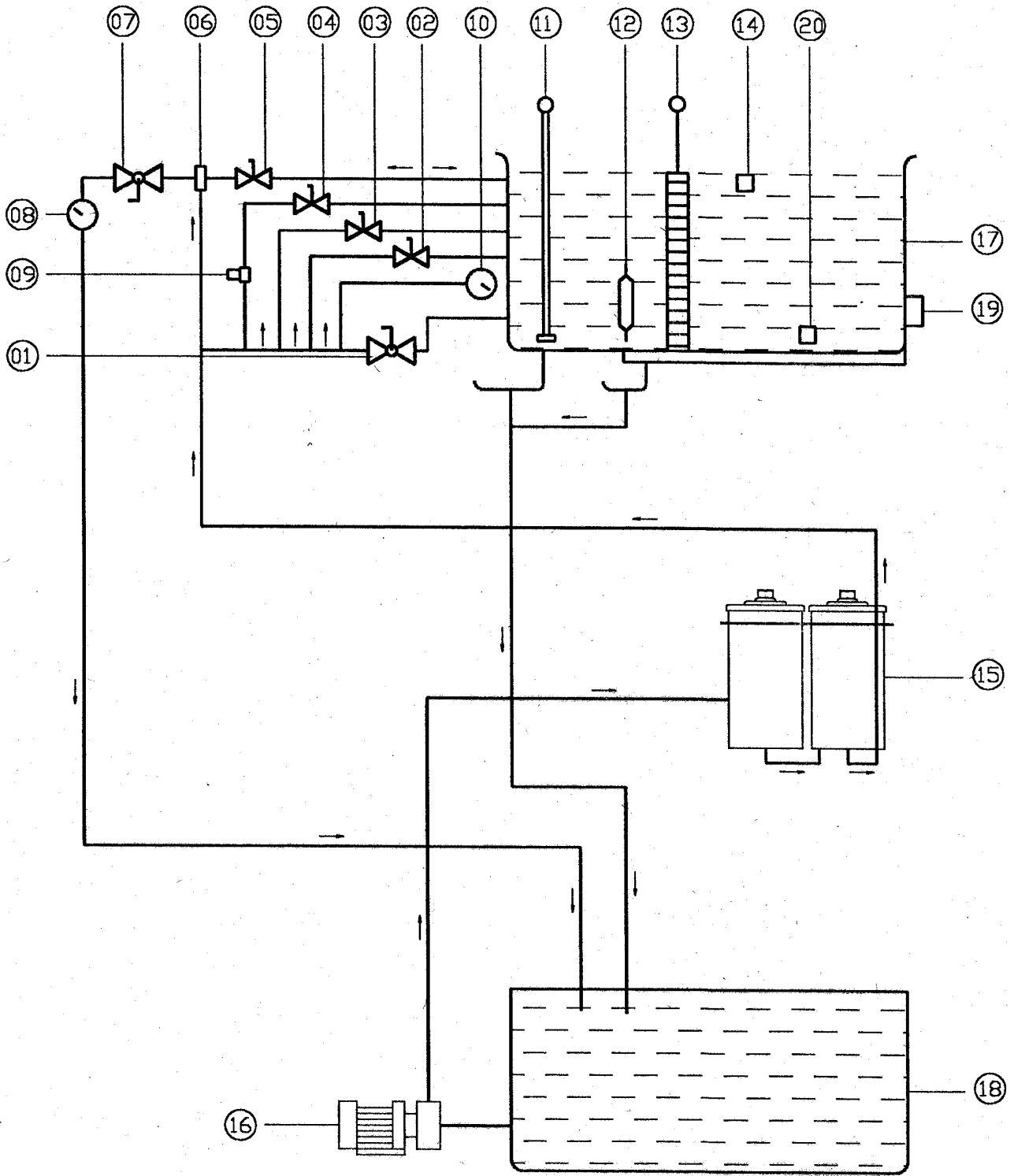

DIELECTRIC CIRCULATION

CHAPTER 6 : MACHINE OPERATION

6-1 SETTING UP THE ELECTRODE

1. PUT THE ELECTRODE INTO THE HOLDER AND FIX IT BY THE SCREW (IN FIG. 6-1B).
2. FIX 2 SETS OF DIAL GAUGE ON WORK TABLE (FIG. 6-1C), CHECK IF THERE IS ANY DEVIATION BY MOVING THE Z AXIS UP-DOWN ARROWKEY OF MANUAL CONTROL PANEL. CHECK THE VERTICALITY BETWEEN ELECTRODE AND WORK TABLE AND ADJUST BY THE 4 SCREWS (FIG.6-1A).
3. FIX 1 DIAL GAUGE ON THE WORK TABLE (FIG. 6-1D), AND MOVE X,Y AXIS FOR CHECKING IF THERE IS ANY DEVIATION OF HORIZONTALLY .
4. WHEN YOU ADJUST THE VERTICAL ADJUSTMENT SCREWS (FIG.6-1A-B) OR THE ANGULAR ADJUSTMENT SCREWS (FIG.6-1A) YOU MUST LOOSEN AND TIGHTEN IN OPOSITE PAIRS TO ACHIVE A SECURE ELECTRODE POSITION.

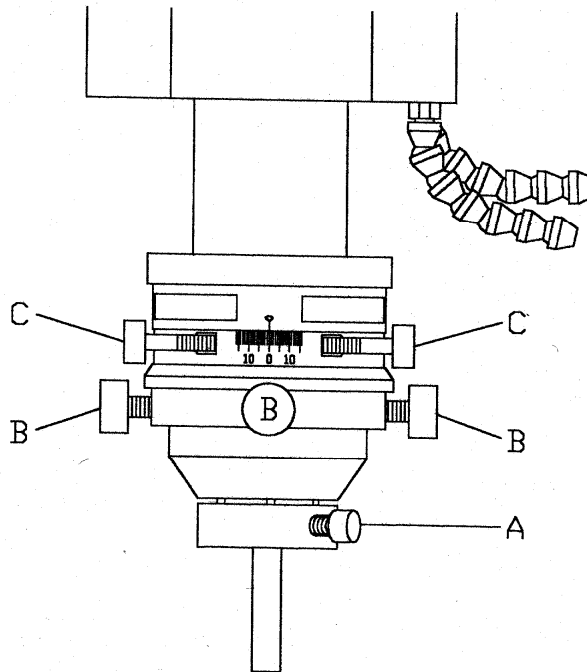

FIG. 6-1A

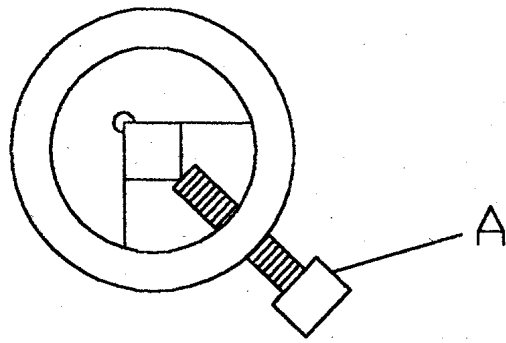

FIG. 6-1B

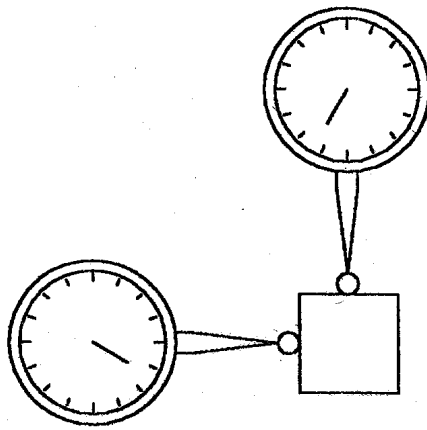

FIG. 6-1C

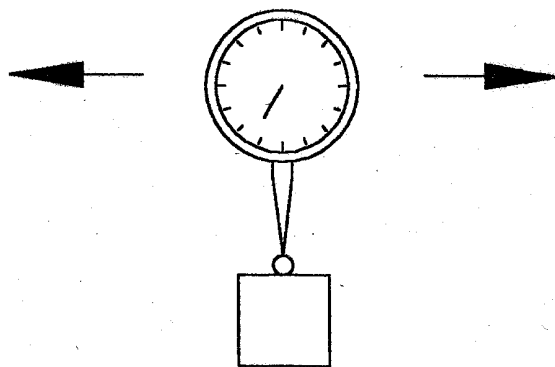

FIG. 6-1D

6-2 CLAMPING WORKPIECE ON THE TABLE

1. FIX THE WORKPIECE BY THE WORK FASTENING TOOL-KIT.(AS FIG. 6-2A)
2. FIX THE WORKPIECE BY THE PERMANENT MAGNETIC CHUCK.(AS FIG. 6-2B)
3. CHECK THE HORIZONTALITY OF WORKPIECE BEFORE FIXING.
YOU CAN FIX THE DIAL GAUGE ON THE CHUCK OF ELECTRODE (AS 6-2C) ,AND
MOVE THE X,Y AXIS FOR CHECKING IF THERE IS ANY DEVIATION OF HORIZONTALITY.

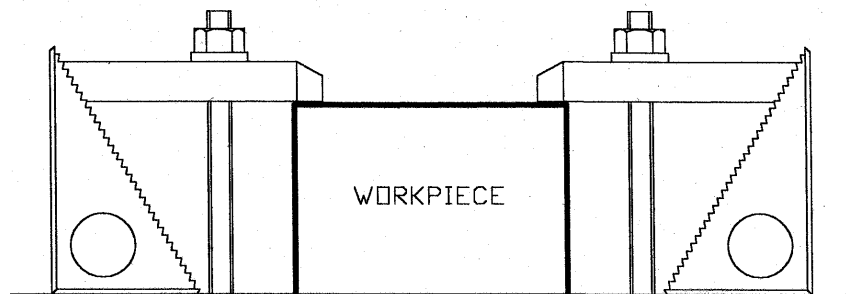

FIG. 6-2A

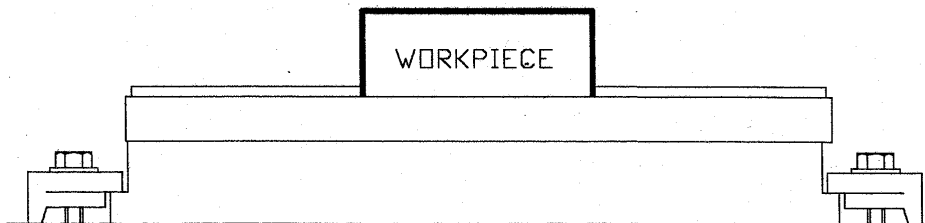

FIG. 6-2B

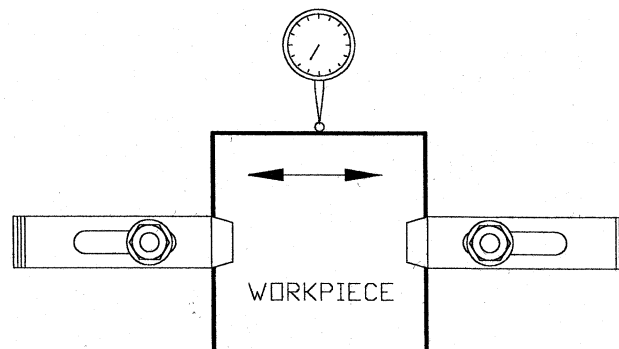

FIG. 6-2C

6-3 ADJUSTING THE TABLE

1. PRESS F1 FUNCTION KEY ON MAIN SCREEN, THEN THE SCREEN WILL BE CHANGED TO NEXT PAGE IN WHICH THE OPERATOR CAN CHOOSE THE SPEED OF MACHINE MOVEMENT.
2. MANUAL MOVEMENT HAS FOUR SPEEDS, I.E., F1: LOW SPEED, F2: MEDIUM SPEED, F3: HIGH SPEED, F4: RAPID SPEED. A FLASHING SIGN SHOWS ON THE SPEED BLOCK WHICH IS SELECTED. IF ONLY ONE OF FOUR SPEED KEYS IS SELECTED THE MACHINE WILL MOVE IN CONTINUOUS MOVEMENT,
3. STEP MOVEMENT FUNCTION IS SET BY PRESSING F7 KEY AND ONE OF THE SPEED KEYS (F1-F4) IE:
PRESS F4 RAPID KEY AND F7 STEP KEY, THE MACHINE WILL MOVE 1 MM EACH STEP.
PRESS F3 HIGH KEY AND F7 STEP KEY, THE MACHINE WILL MOVE 0.1 MM EACH STEP.
PRESS F2 MEDIUM KEY AND F7 STEP KEY, THE MACHINE WILL MOVE 0.01 MM EACH STEP.
PRESS F1 LOW KEY AND F7 STEP KEY, THE MACHINE WILL MOVE 0.001 MM EACH STEP.

MANUAL MOVEMENT CAN ALSO BE CONTROLLED FROM THE HAND CONTROL BOX, SHOWN BELOW. THE OPERATOR CAN PRESS THE FUNCTION KEY AND DIRECTION ON HAND CONTROL BOX, BUT THERE IS ONE IMPORTANT KEY (INDICATED SWITCH - "A" OF HAND CONTROL BOX).

WHEN "A" SWITCH IS "OFF", A SHORT CIRCUIT BETWEEN THE ELECTRODE AND WORKPIECE WILL STOP THE MOVEMENT OF Z-AXIS TO PROTECTING THE WORKPIECE, THE ALARM BUZZER AND INDICATOR LAMP WILL ACTIVATE.

WHEN "A" SWITCH IS "ON" THE ELECTRODE AND WORKPIECE CAN HIT WITH NO PROTECTION.

USE THIS FUNCTION WITH CARE

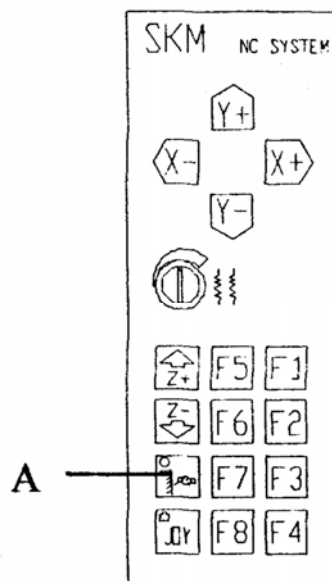

(A. ALIGN SWITCH & LIGHT)

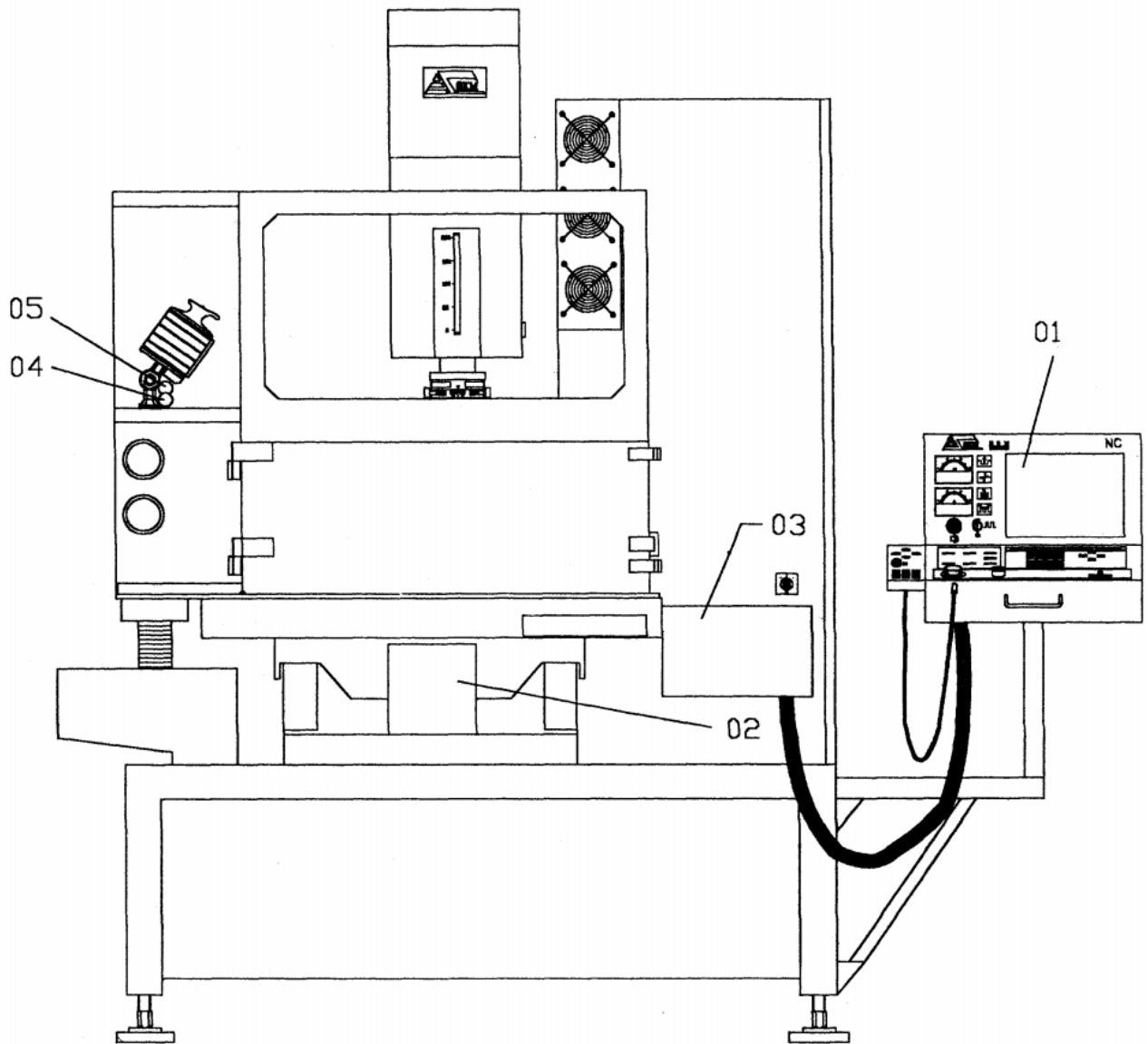

01 - REMOTE CONTROL PANEL
02 - Y AXIS MOTOR
03 - X AXIS MOTOR

04 - THE DRAIN KNOB
05 - OVERFLOW CONTROL KNOB

FIG. 6-3

6-4 CLOSING THE DOOR OF WORK TANK

CHECK THAT IT LOCKS AFTER CLOSING THE DOOR.

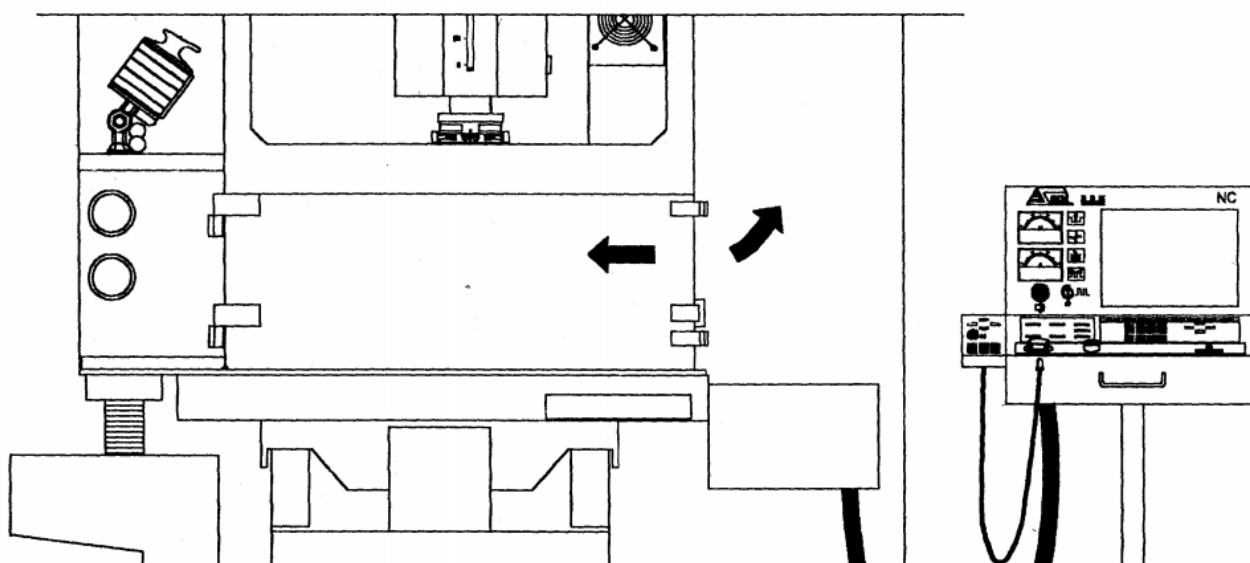

FIG. 6-4

6-5 WORK TANK

PLEASE REFER TO CHAPTER 6 FOR OPERATING THE WORK TANK & DIELECTRIC FLUID.

1. FILLING THE WORK TANK:

OPEN TANK FILL VALVE BY TURNING THE HANDLE (FIG. 6-5A) TO THE HORIZONTAL POSITION, SWITCH THE PUMP “ON ” AT THE CONTROL PANEL. TURN THE TANK FILL VALVE HANDLE TO THE VERTICAL POSITION WHEN THE DIELECTRIC FLUID COVERS THE WORKPIECE BY APPROX. 30-50MM.

2. THERE ARE 5 FLUSHING OUTLETS. (FIG. 6-5B)

A. CONTINUOUS INJECTION.

B. CONTINUOUS INJECTION.

C. PULSED INJECTION SYNCHRONIZED WITH PULSATION OF THE ELECTRODE.

D. INJECTION AND SUCTION COMBINED.

E. CONTINUOUS FLUSHING AT WORKHEAD.

REMARK:

⇒ THE FLUSHING VALVES CONTROL THE FLUSHING ACTION, EITHER STRONG OR WEAK.

WHEN MACHINING, THE DIELECTRIC FLUID LEVEL MUST BE MAINTAINED BETWEEN 30-50MM OVER THE SURFACE OF THE WORKPIECE.

⇒ WHEN FINISH MACHINING, OPEN THE TANK DOOR AND CLEAN THE WORKPIECE WITH THE AID OF A SPONGE STICK .

⇒ CHECK THAT THE WORK TANK IS EMPTY OF OIL BEFORE OPENING THE TANK DOOR?

⇒ IT IS BETTER TO USE THE MAGNETIC OIL NOZZLE BASE OR FLUSHING PIPE, IT CAN KEEP THE QUALITY & SPEED OF SPARKING .

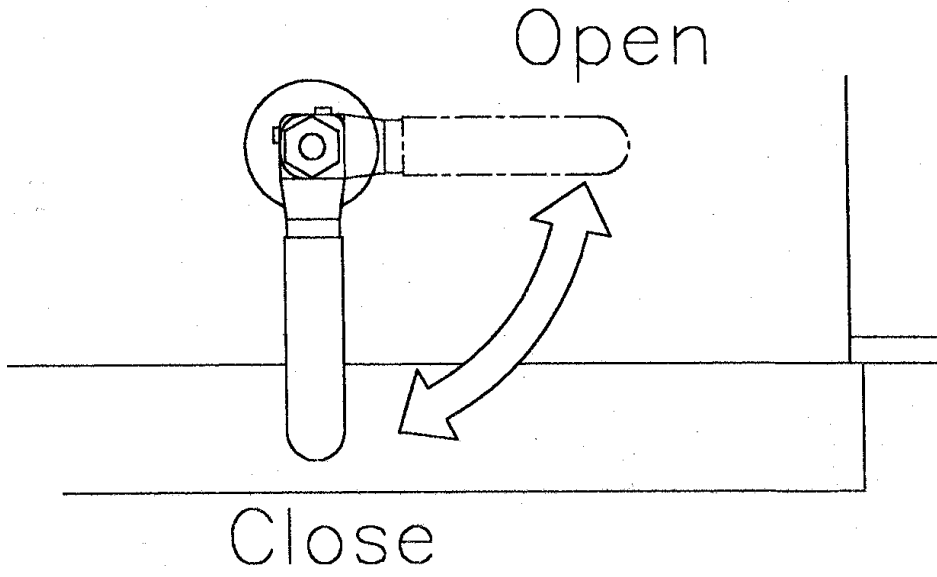

FIG. 6-5A

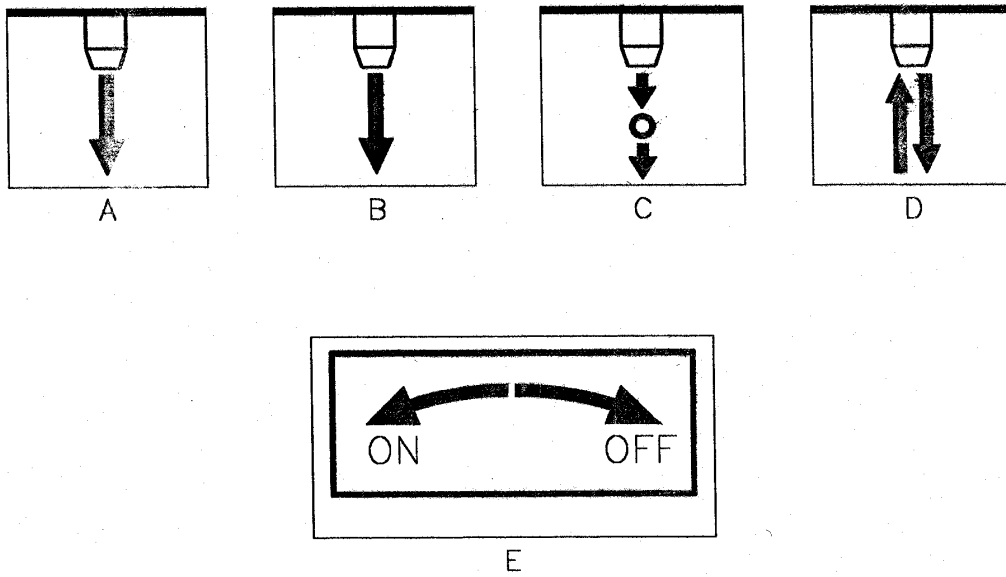

FIG. 6-5B

30 A 45 A 60 A GENERATOR

CHAPTER 1 : SKM GENERATOR INTRODUCTION

CHAPTER 2 : EDM PRINCIPLES AND TECHNOLOGY

2-1 THE INTENDED USE

CHAPTER 3 : ELECTRODE MATERIAL

3-1 CHARACTERISTICS OF ELECTRODE MATERIAL

3-2 ELECTRODE MANUFACTURING

CHAPTER 4 : EDM APPLICATION

4-1 DISCHARGE OPERATION PROCESS

4-2 SAMPLE

CHAPTER 5 : ZNC SYSTEM INSTRUCTION

5-1 PROGRAMMING EDM FUNCTION

5-2 REFERENCE PLANE SYSTEM



5-3 OPERATION DESCRIPTION

CHAPTER 6 : OPERATIONAL INTRODUCTION

6-1 CONTROL PANEL & REMOTE CONTROL INTRODUCTION

6-2 THE FUNCTIONS OF CONTROL PANEL & REMOTE CONTROL

CHAPTER 7 : DESCRIPTION OF EDM PARAMETERS

- 7-1 “MFD” FINE MIRROR FINISH AMPERAGE CONTROL
- 7-2 “BP” HIGH VOLTAGE AMPERAGE CONTROL
- 7-3 “AP” LOW VOLTAGE AMPERAGE CONTROL
- 7-4 “TA” PULSE “ON” DURATION
- 7-5 “TB” PULSE “OFF” DURATION
- 7-6 “” SERVO SENSITIVITY ADJUST SWITCH
- 7-7 “” DISCHARGE GAP CONTROL
- 7-8 “” WORK HEAD VERTICAL UP DOWN MOVEMENT ADJUSTMENT
- 7-9 POLARITY REVERSE CONTROL SWITCH, LARGE-AREA FINISH
FUNCTION, DEPTH-HOLD & SIDE SERVO FUNCTION
- 7-10 BUZZER AND DISCHARGE TIMER
- 7-11 EMERGENCY STOP, MAIN-SWITCH
- 7-12 WORK LIGHT & FIRE ALARM OPERATION DESCRIPTION

CHAPTER 8 : NC SYSTEM APPLICATION

- 8-1 SYSTEM APPLICATION
- 8-2 MANUAL MOVEMENT
- 8-3 AUTO MOVEMENT
- 8-4 EDGE FINDING
- 8-5 MANUAL SPARKING
- 8-6 PROGRAMMING
- 8-7 SET UP PARAMETER
- 8-8 FINE FINISHING

CHAPTER 9: BRIEF MAINTENANCE

ENCLOSED 30A 45A 60A APPLICATION NOTE

CHAPTER 1 : SKM GENERATOR INTRODUCTION

SKM EDM SYSTEM CONTROL BOX (SEE FIG 1), THE HARDWARE UTILIZED IS A 32-BIT INDUSTRIAL-USE HIGH SPEED COMPUTER FOR STABILITY, DURABILITY AND MATCHED POSITION CONTROL PRECISION.

Basic Functions

- INNOVATIVE EQUIPMENT WITH THREE TYPES OF SAFETY DEVICES, HAS AN INFRARED FIRE MONITOR, OIL TEMPERATURE MONITOR, AUTOMATIC FIRE EXTINGUISHER AND MANY OTHER SAFETY DESIGN FEATURES TO PROVIDE FIRE PROTECTION.
- HAS AN AUTOMATIC SPARKING OFF TIME ADJUSTMENT TO PREVENT CARBON ACCUMULATION AND ELECTRODE WEAR.
- OPTIONAL AMPERAGE TUNING, PROVIDING 30A, 45A, 60A, 90A, 120A OR HIGHER OUTPUT POWER .
- INTEGRATED DESIGN WITH AUTOMATIC DETECTION SYSTEM, AUTOMATIC CURRENT PROTECTION CONTROL, TRANSISTOR OVERLOADING PROTECTION, RADIATOR DEVICES AND METAL SHELL GROUNDING DEVICE TO PREVENT MISCELLANEOUS MALFUNCTIONS.
- ELECTRONIC APPARATUS BUILT WITH EUROPEAN, AMERICAN AND JAPANESE PRODUCTS, ALL COMPLYING WITH STANDARDS AND STRICT TESTING, THEREFORE, IT IS RELIABLE AND EASY TO MAINTAIN.

THESE FEATURES PROVIDE HIGH EFFICIENCY ZNC CONTROL AND A SAFE WORKING ENVIRONMENT.

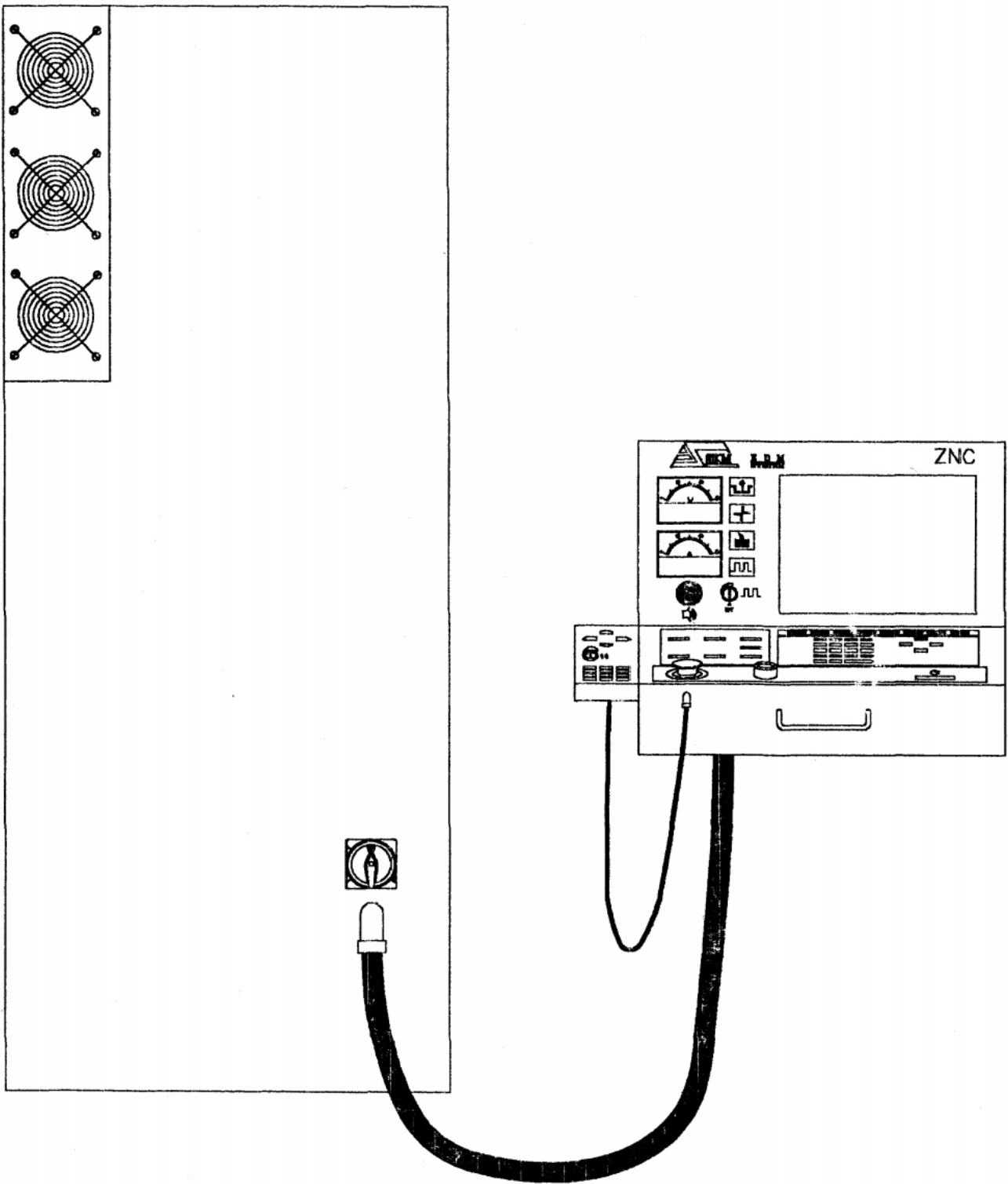
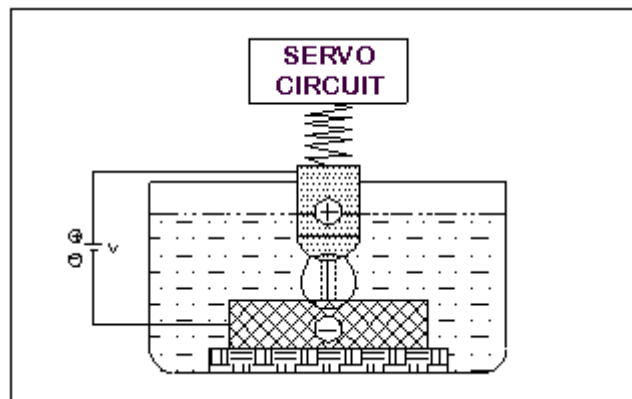

FIG. 1

CHAPTER 2 : EDM PRINCIPLES AND TECHNOLOGY

ELECTRICAL DISCHARGE MACHINING INVOLVES THE FLOWING OF A DIELECTRIC FLUID BETWEEN THE WORK PIECE AND THE ELECTRODES, WHEREIN DIRECT CURRENT IS NORMALLY UTILIZED TO MAINTAIN POLE VOLTAGE TO PRODUCE AN ELECTRICAL POTENTIAL. THE ELECTRODE FEED, SUCH AS SERVO MOTOR IS CONTROLLED TO GIVE A PRECISE POLE GAP DISTANCES (WITHIN APPROXIMATELY 0.02MM-0.1MM) TO PRODUCE A HIGH MAGNITUDE ELECTRIC FIELD THAT OVERCOMES THE INSULATING PROPERTIES OF THE DIELECTRIC FLUID TO GENERATE AN ELECTRICALLY CONDUCTIVE IONIZED CHANNEL OF FREE FLOWING ELECTRONS AS THE PRODUCED ELECTRIC CURRENT. THIS TYPE OF CURRENT DOES NOT REQUIRE CONDUCTORS TO TRANSMIT THE PRODUCED FLOW OF CURRENT AND WE CALL IT AN ISOLATED ELECTRIC DISCHARGE REACTION. IN THIS PHENOMENON, ELECTRICAL ENERGY IS INSTANTANEOUSLY TRANSFORMED INTO AN ULTRA-HIGH HEAT LEVEL OF APPROXIMATELY 10,000°C. DUE TO THE TRANSFORMATION OF THE ENERGY, THE HIGH-TEMPERATURE HEAT PRODUCED MELTS TO THE SURFACE OF THE WORK PIECE. BY UTILIZING THIS REACTION, WE CAN FABRICATE ELECTRODES OF DIFFERENT SHAPES TO ERODE A RANGE OF DIFFERENT EXTERIOR CONTOURS IN THE WORK PIECE.



1. WHEN VOLTAGE IS APPLIED TO THE ELECTRODE AND THE WORK PIECE, AN ELECTRICAL FIELD FORMS AS THE VOLTAGE BUILDS UP, GETTING STRONGER WHEN THE DISTANCE BETWEEN ELECTRODE AND WORK PIECE GETS CLOSER.

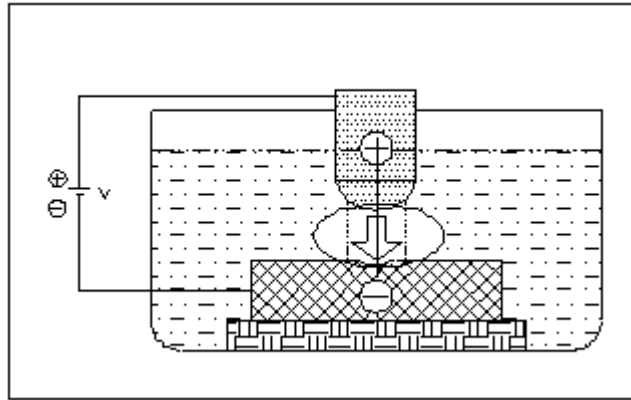

2. WHEN THE POLE DISTANCE BETWEEN THE ELECTRODES AND THE WORK PIECE REACHES THE APPROPRIATE VALUE, THE INSULATION BREAKDOWN PRODUCES HIGH-IMPACT IONIZATION DUE TO THE INTENSIFICATION OF THE ELECTRIC FIELD. THE ELECTRICAL ENERGY IS INSTANTLY TRANSFORMED INTO HEAT ENERGY TO ERODE THE WORK PIECE, RESULTING IN THE FORMING OF CAVITATION AND PRODUCING OF CARBON RESIDUES AND SO ON. MEANWHILE, THE DIELECTRIC FLUID DISINTEGRATES INTO AN AIRBORNE GAS THAT RAPIDLY EXPANDS OUTWARD.

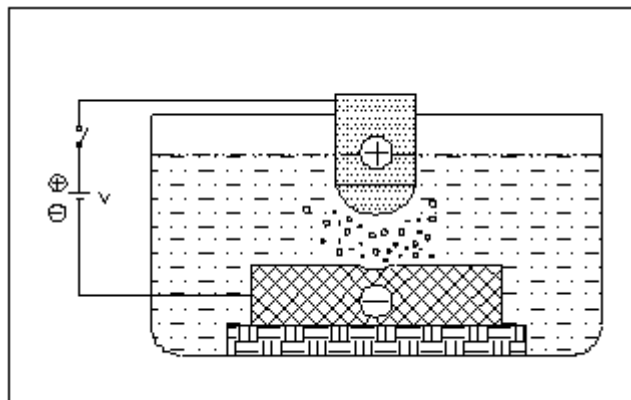

3. THE TRANSPORTATION ENERGY AT THE CENTER POINT BETWEEN THE ELECTRODES IS CUT OFF THROUGH DIELECTRIC RESOLUTION, WHICH IS MANIFESTED AS A SPARKING ELECTRICAL DISCHARGE OF THE DIELECTRIC FLUID. AT THIS TIME, HIGH-TEMPERATURE GASES ARE ABSORBED INWARDLY. THE MOLTEN MATERIAL OF THE WORK PIECE CONTINUES TO FLOW AND BE REMOVED AS THE DIELECTRIC FLUID DISINTEGRATES.

AFTER KNOWING THE PRINCIPLES AND PHYSICAL CHARACTERISTICS OF EDM, WE WOULD LIKE TO DESCRIBE THE RELATIVE FACTORS OF EDM THAT INFLUENCE EFFICIENCY. CAREFUL CONTROL OF THOSE VARIABLES GAP, POLARITY, AMPERAGE, DURATION IS ESSENTIAL TO BE SURE OF MACHINING AT MAXIMUM EFFICIENCY. FOR EXAMPLE, POLARITY SELECTION; MATCHING THE AMPERAGE AND DURATION, THE ELECTRODE WEAR MAY VARY FROM 0.1% TO 99.8%.

2-1 INTENDED USE :

ELECTRICAL DISCHARGE MACHINE IS IDEAL FOR ACHIEVING TIGHT TOLERANCES THAT WOULD BE EXTREMELY DIFFICULT TO MACHINE USING OTHER METHODS. IT CAN WORK ON METAL WORKPIECE LIKE STEEL, ALUMINUM, STAINLESS STEEL , ALLOY STEEL, AND COPPER. THE WORKING ELECTRODE MATERIAL CAN USE COPPER, GRAPHITE AND COPPER TUNGSTEN ALLOY.

CHAPTER 3 : ELECTRODE MATERIAL

ANY MATERIAL WHICH IS A GOOD ELECTRICAL CONDUCTOR CAN BE USED. MATERIALS WITH THE HIGHEST MELTING POINT AND THE LOWEST ELECTRICAL RESISTIVITY ARE THE BEST. BECAUSE ELECTRODE COST IS CRITICAL FACTOR IN COST ANALYSIS, SELECTION OF ELECTRODE MATERIAL, THE QUANTITY AND THE METHOD OF MANUFACTURE ARE ALL IMPORTANT AND NEED CAREFUL CONSIDERATION.

ELECTRODE MATERIALS CAN USUALLY BE DIVIDED AS FOLLOWS:

1. SILVER TUNGSTEN
2. COPPER TUNGSTEN
3. COPPER GRAPHITE
4. CHROMIUM COPPER
5. ELECTROLYTIC COPPER
6. GRAPHITE
7. BRONZE
8. ALUMINUM ALLOY
9. STEEL

OF ALL THE ABOVE, ELECTROLYTIC COPPER IS THE MOST POPULAR. SILVER TUNGSTEN, COPPER TUNGSTEN ARE BOTH QUITE EXPENSIVE , SO THEY ARE USUALLY USED TO VERY SMALL AND HIGH PRECISION PARTS. AFTER COST, THE MOST IMPORTANT FACTORS IN ELECTRODE SELECTION ARE LOW WEAR AND EASE OF ELECTRODE MANUFACTURING.

GRAPHITE FEATURES ARE LOW ELECTRODE WEAR AND HIGH REMOVAL RATE, BUT BREAKS EASILY AS LOW DENSITY. SO IT IS BEST EMPLOYED WHEN FINE FINISH IS NOT REQUIRED.

STEEL IS MOST UTILIZED IN THE TOOLING OF SPLIT LINES PLASTIC AND DIE CASTING MOLD.

3-1 ELECTRODE MATERIALS CHARACTERISTICS

ELECTRODE MATERIAL	MELTING POINT	RESISTIVITY $\Omega \text{ mm}^2 / \text{m}$	DENSITY g / mm^3
SILVER TUNGSTEN		0.048	0.016
COPPER TUNGSTEN		0.055	0.015
COPPER GRAPHITE'S		0.04	0.027
CHROMIUM COPPER		0.0236	0.0081
ELECTROLYTIC COPPER	1083	0.0167	0.0089
GRAPHITE'S	3700	0.085~0.15	0.0015~0.0018
BRONZE	1060		0.0082
ALUMINUM ALLOY			
STEEL	1539	0.0971	0.0087

3-2 ELECTRODE MANUFACTURING

1. TRADITIONAL MACHINING METHODS SUCH AS TURNING, MILLING, SHAPING, GRINDING, ENGRAVING, ...ETC.
2. STAMPING
3. EXTRUSION OR DRAWING
4. GALVANIC PLATING

THE ABOVE METHODS OF PRODUCTION ARE ALL SUITABLE. SELECTION OF ONE DEPENDS ON ELECTRODE MATERIAL.

- ◆ COMPLEX OR CONVOLUTED ELECTRODE SHAPE: IT MAY BE PRODUCED IN SEPARATED PARTS.
- ◆ IRREGULAR ELECTRODE SHAPE: IT MUST BE CENTERED ON EASILY MEASURE AXIS.
- ◆ LONG, THIN ELECTRODES : HAVE TO BE INSTALLED WITH CURRENT SUPPLIED TO THE ENDS AS WELL AS THE CENTER THEREBY ENSURING EVEN DISCHARGE OVER WHOLE WORK PLACE. (FIG.3-1)
- ◆ A SMALL DIAMETER HOLE REQUIRE PIPES ELECTRODE: TO ENSURE HIGH EFFICIENCY IN FLUSHING AND DRAINING.(FIG.3-2)
- ◆ FOR THROUGH THE HOLE MACHINING ENSURE WORK HEAD ELECTRODE IS THIN. THICK ELECTRODES IMPEDE PARTICLE DISCHARGE. (FIG.3-3)

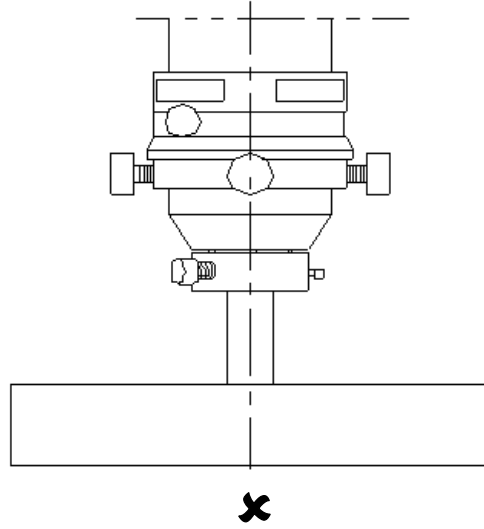
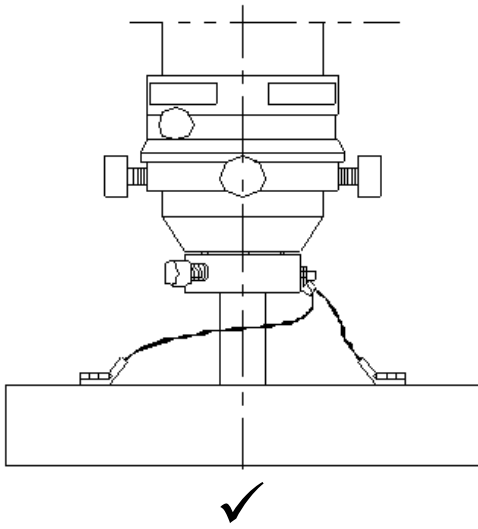

FIG. 3-1

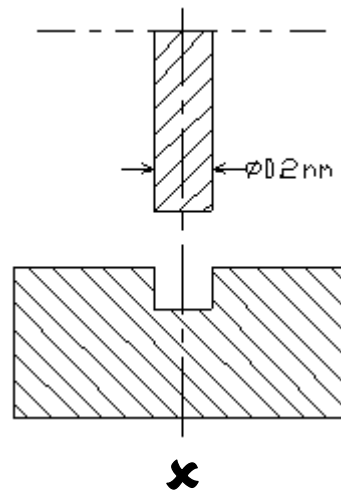
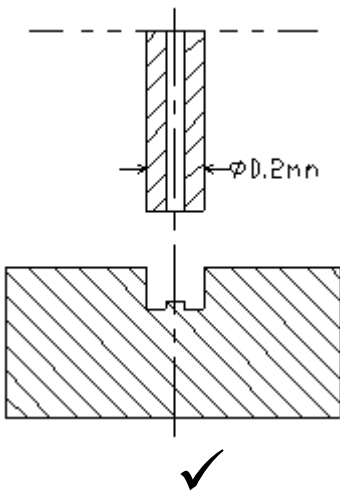

FIG. 3-2

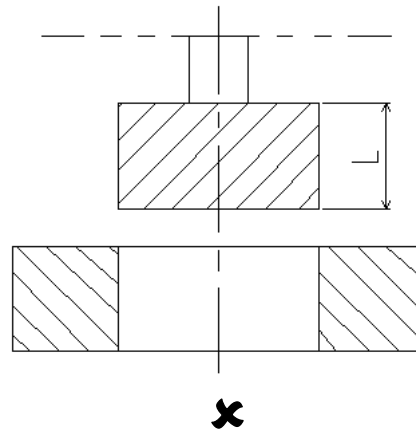
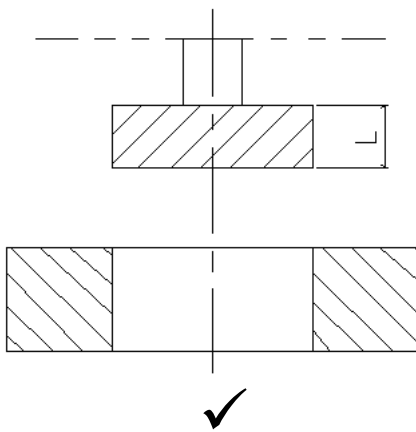

FIG. 3-3

CHAPTER 4 : EDM APPLICATION

EDM APPLICATIONS DEPENDS ON A SKILLED OPERATOR TO ANALYZE ALL THE EDM FACTORS TO PRODUCE HIGH QUALITY WORK.

1. ELECTRODE MATERIAL
2. WORKPIECE MATERIAL
3. ELECTRODE VOLUME
4. SURFACE FINNISH
5. SPARK GAP
6. ELECTRODE WEAR
7. REMOVAL RATE

(THE ABOVE FACTORS ARE EXPLAINED IN THE ENCLOSING 30A 45A 60A APPLICATION NOTE)

DURING SPARKING (DISCHARGE) THE GAP AREA MUST BE CONTINUOUS FLUSHED TO CLEAN OFF PARTICLES AND RESIDUE, AND THE DIELECTRIC FLUID HAS TO KEEP CLEANING.

IF FLUSHING AND DRAINING OF THE CAVITY IS NOT GOOD ENOUGH, INCREASE THE SERVO TO HIGHER SETTING. TO GET FINE FINISH, THE VERTICAL MOVEMENT MUST BE VERY FAST.

TO ACHIEVE LOW OR NO ELECTRODE WEAR, START WITH A LOW DISCHARGE AMPERAGE, AND AS SOON AS THE WHOLE AREA OF ELECTRODE CONTACTS THE WORK PIECES, INCREASE AMPERAGE. THIS WILL PROTECT SHARP CORNER OR ANGLES.

TO SET SERVO SENSITIVITY BEAR IN MIND SENSITIVITY DEPENDS ON CURRENT; WHEN THE CURRENT IS LOW, THEN USE LOW AMPLITUDE AND HIGH SENSITIVITY.

4-1 DISCHARGE OPERATION PROCESS

1. TURN ON THE MAIN SWITCH IN “ON” POSITION.
↓
2. ELECTRODE ZERO VERTICAL ANGLE AND AT POSITION “0” .
↓
3. FINDING X.Y AXIS‘ REFERENCE POINT , SET UP THEIR POSITION.
↓
4. MOVING Z AXIS TO REFERENCE POINT, AND CLEAR IT‘S VALUE TO “0” .
↓
5. SETTING SERVO SENSITIVITY, AND SPARKING PARAMETERS.
↓
6. SETTING SYNCHRONOUS FLUSHING SWITCH AND OVERFLOW CONTROL SWITCH & WORK HEAD LIFT CONTROL.
↓
7. DIELECTRIC PUMP AND FIRE CONTROL LAMP “ON” , ADJUST OVERFLOW GATE.
↓
8. DISCHARGE SWITCH “ON” .
↓
9. OBSERVE THE VOLTAGE & AMPERAGE METERS, AND THE REACTION OF Z AXIS TO CHECK WHETHER THEY ARE STABLE WHEN SPARKING.

(REMARK : DO NOT TOUCH THE WORK HEAD & ELECTRODE WHEN SPARKING.)

4-2 THE SAMPLE OF SPARKING

- 1. SPARKING FOR CUTTING (FIG. 4-1)
- 2. SPARKING FOR GRINDING (FIG. 4-2)
- 3. SPARKING FOR CARVING (FIG. 4-3 AND FIG. 4-4)

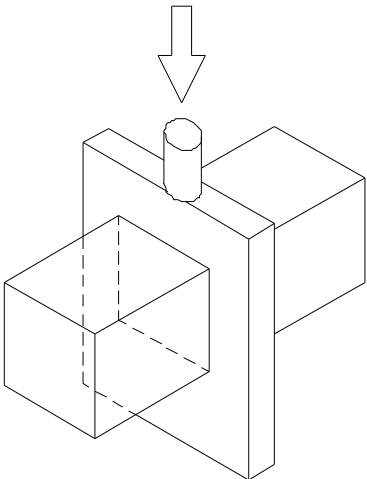

FIG. 4-1

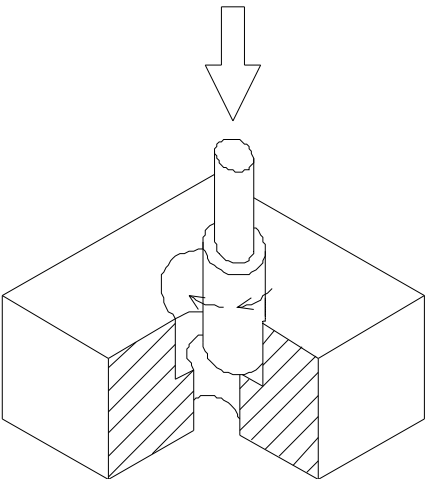

FIG. 4-2

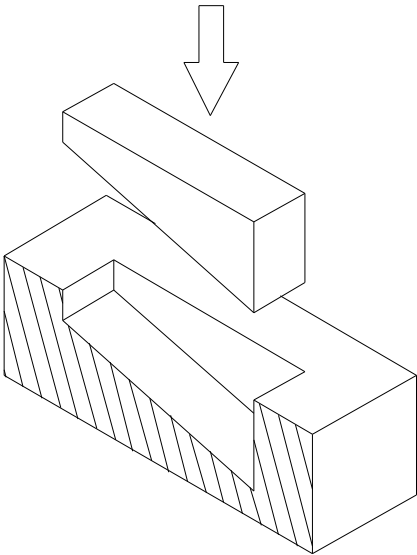

FIG. 4-3

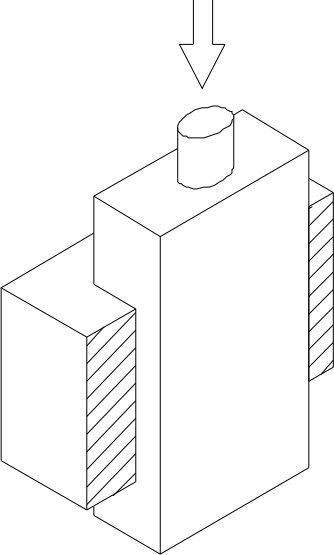

FIG. 4-4

CHAPTER 5 : K60 NC SYSTEM INSTRUCTION

5-1 PROGRAMMING EDM FUNCTION

CHARACTERISTICS OF K60 NC :

1. PROGRAMMABLE FUNCTION :

SUPPORTS SINGLE-HOLE AND MULTI-HOLE SINGLE-DEPTH OR MULTI-DEPTH AUTOMATIC FINE FINISHING.

THE PROGRAMMING FACTORS INCLUDE- DEPTH OF Z-AXIS, THE POSITION OF X , Y AXIS, DISCHARGE PARAMETER AND SPARKING TIMER.

THE OPERATION CAN DO THE ROUGH FINISH, MIDDLE ROUGH FINISH, AND FINE FINISH WORK BY SETTING PROGRAM.

2. MEMORIZING PROGRAM:

SPARKING CONDITIONS AND PROCESSING SETTING CAN BE STORED IN MEMORY, AND RECALLED FOR REPEAT INSTANCES OF THE JOB.

3. SPARKING PERIOD SETTING:

HAS A SPARKING PERIOD SERVO THAT SUPPORTS THE ACTIVE UTILIZATION OF FINISHING DEPTH. THIS FUNCTION CAN REPLACE OF THE Z-AXIS DEPTH SETTING. WHEN YOU SET THE SPARKING TIME AND ALSO Z-AXIS SPARKING DEPTH, THE MACHINE WILL STEP TO THE NEXT PROGRAM BLOCK OR STOP SPARKING IF ONE OF THESE TWO PRESETS IS REACHED.

4. SURFACE FINISHING RATE:

OPTIONAL MIRROR SURFACE FINISHING SYSTEM CAN BE INSTALLED TO ACHIEVE ULTRA-FINE SURFACE FINISHING OF MORE THAN RA0.2UM.

5. MEASUREMENT FEEDBACK:

THREE-AXIS LOCATIONS UTILIZES OPTICAL MEASUREMENT FEEDBACK FOR HIGH PRECISION POSITIONING. THE OPTICAL MEASUREMENT RESOLUTION CAN BE ADJUSTED IN GRADATION OF 1 UM OR 5 UM.

6. MEASUREMENT EXCHANGE:

HAS METRIC AND INCH MEASUREMENT UNITS AS WELL AS CHINESE AND ENGLISH LANGUAGE SWITCHING FUNCTIONS.

7. POSITION MEMORIZING:

HAS THE FUNCTION OF MEMORIZING THE SETTING POSITION, IT CAN SAVE THE LAST SETTING POSITION AND CONTINUE MACHINING AFTER A POWER CUT.

8. DIRECTION CONTROL:

OPTICAL MEASUREMENT DIRECTION CAN BE SET OR MODIFIED BY INTERNAL CODE.

9. AUTOMATIC FINDING EDGE:

OPERATOR CAN USE FUNCTION KEY TO PROCEED THE X ,Y, Z AXIS AUTOMATIC EDGE FINDING.

10. AUTO HALVE CALCULATION:

IT CAN FIND THE CENTER VALUE OF WORKPIECE.

11. 14" MONITOR:

FOR CHOOSING THE FUNCTION KEY AND OBSERVING THE SPARKING CONDITIONS EASILY.

5-2 REFERENCE PLANE SYSTEM

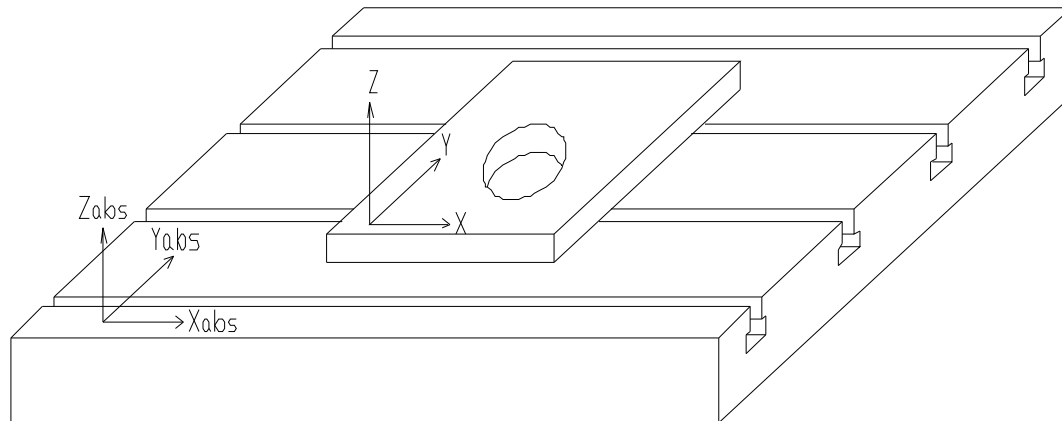

FIG. 5-1

THERE ARE 2 TYPES OF SYSTEMS OF REFERENCE PLANE (FIG. 5-1) :

1. ABSOLUTE VALUE:

THIS IS THE REFERENCE VALUE AFTER FINDING EDGE, AND IT WILL BE STORIED PERMANENTLY, EXCEPT WHEN RESET TO A NEW VALUE.

2. RELATIVE VALUE:

THE RELATIVE (FIG. 5-2) VALUE IS DISPLAYED BY SMALL LETTERS ON THE MONITOR AND CAN BE CHANGED OR VIEWED.

	ABSOLUTE VALUE	RELATIVE VALUE
X	0.000	X - 3.000
Y	0.000	Y - 2.000
Z	-10.000	Z - 10.000

FIG. 5-2

5-3 OPERATION DESCRIPTION

1. PROGRAM EDIT MODE:

USE THE NUMERICAL OR FUNCTION KEYS OF CONTROL PANEL TO EDIT THE PROGRAM AND MODIFY THE EDM PARAMETERS .

THE MAIN EXECUTION PROGRAM IS CAPABLE OF ADDING AUXILIARY PROGRAM ROUTINES OR MODIFYING ANY SPARKING CONDITION.

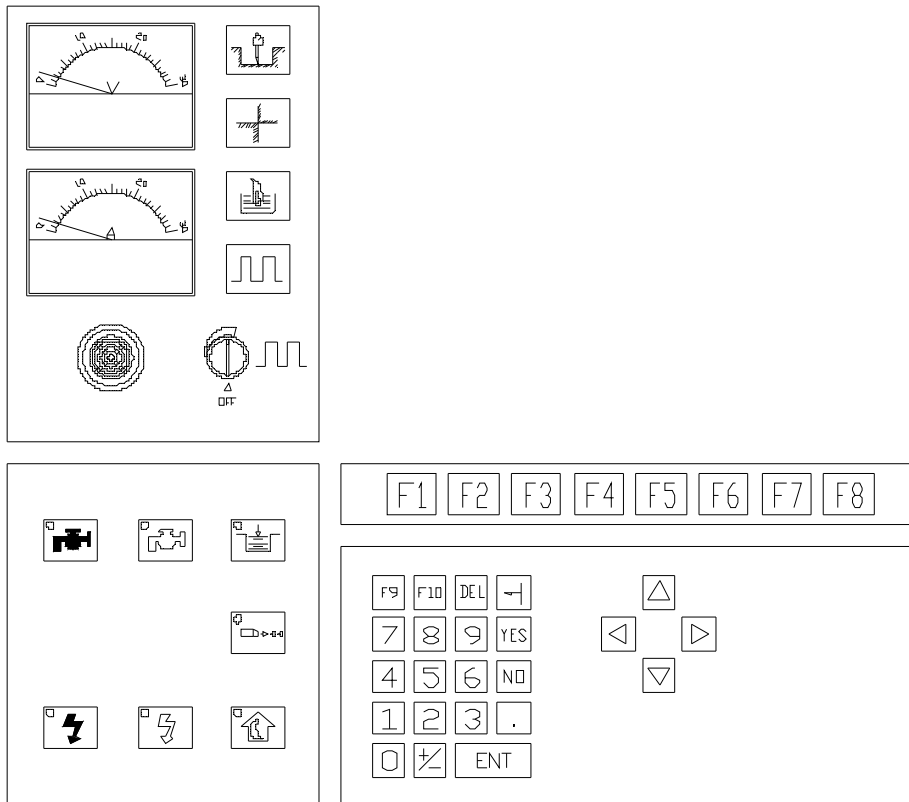

2. THE SPARKING PROCESS:

USE THE KEYS TO CHOOSE THE NECESSARY SPARKING NO. AFTER EDITING THE PROGRAM OR MODIFYING PARAMETERS, THEN PRESS F5 FUNCTION KEY AND PRESS DIELECTRIC FLUID PUMP “ON” SWITCH OR OVERFLOW CONTROL SWITCH (IF NECESSARY), AFTER THIS MACHINE WILL START SPARKING.

CHAPTER 6 : OPERATIONAL INSTRUCTION

A. DESCRIPTION OF CONTROL PANEL

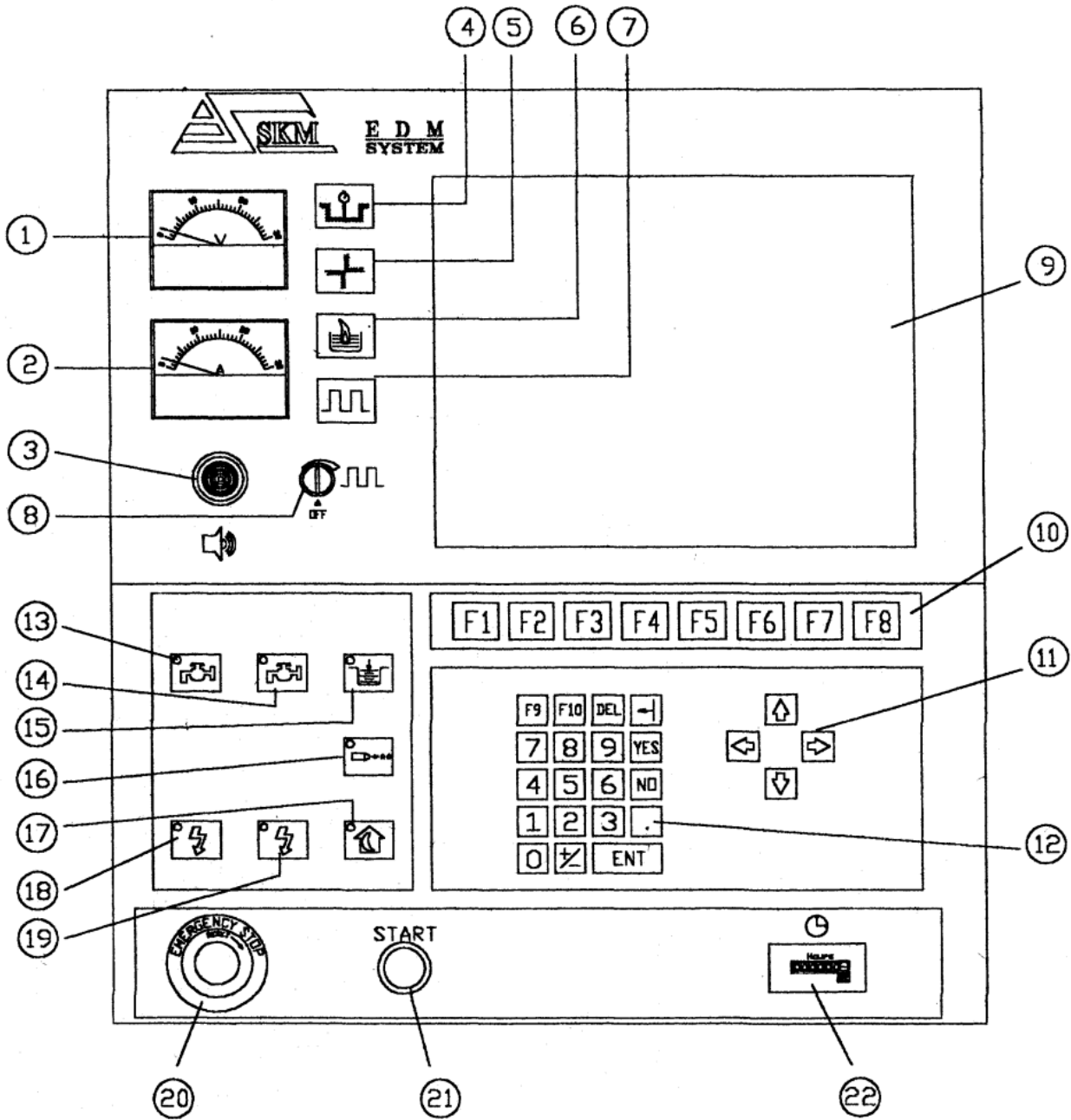

FIG. 6-1

B: MANUAL CONTROL PANEL

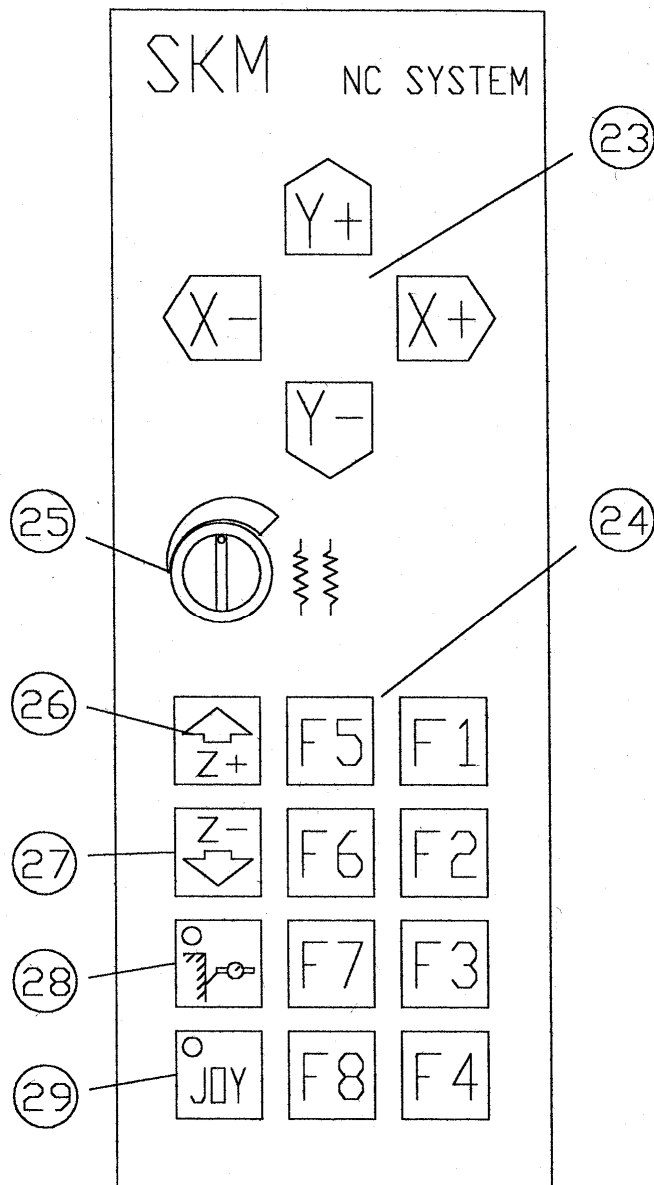

FIG. 6-2

6-1 CONTROL PANEL & REMOTE CONTROL INTRODUCTION

FIGURE 6-1 IS K60 NC EDM SCREEN PAGE, AND FIG.6-2 IS MANUAL CONTROL PANEL DRAWING.

DESCRIPTION OF FUNCTION KEYS ARE AS BELOW:

1. VOLTMETER : FOR SHOWING THE DISCHARGE VOLTAGE.
2. AMMETER : FOR SHOWING THE DISCHARGE AMPERAGE.
3. BUZZER : WARNING SOUND.
4. DEPTH INDICATOR LAMP.
5. EDGE FINDING INDICATOR LAMP.
6. TEMPERATURE/FIRE CONTROL INDICATOR LAMP.
7. ARC INDICATOR LAMP.
8. ANTI-ARC ADJUSTMENT KNOB.
9. MONITOR SCREEN.
10. F1-F8 FUNCTION KEYS.
11. NUMERICAL KEYS.
12. ARROW KEYS.
13. DIELECTRIC FLUID PUMP "ON" SWITCH/LAMP.
14. DIELECTRIC FLUID PUMP "OFF" SWITCH/LAMP.
15. OVERFLOW CONTROL SWITCH/LAMP.
16. SYNCHRONOUS FLUSHING CONTROL LAMP.
17. SLEEP SWITCH/LAMP.

18. DISCHARGE "ON" SWITCH/LAMP.
19. DISCHARGE "OFF" SWITCH/LAMP.
20. START SWITCH.
21. KEY-LOCK SWITCH.
22. DISCHARGE TIMER.
23. X.Y. AXIS SELECTION OF DIRECTION KEY.
24. F1-F8 FUNCTION KEYS (PRESS JOY KEY AND SELECT THIS KEY AT THE SAME TIME) .
25. Z-AXIS SPEED CONTROL KNOB.
26. Z-AXIS UP SWITCH.
27. Z-AXIS DOWN SWITCH.
28. ALIGN, REFERENCE VOLTAGE OFF SWITCH (PRESS JOY KEY AND THIS KEY AT THE SAME TIME).
29. JOY KEY.

6-2 THE FUNCTIONS OF CONTROL PANEL & REMOTE CONTROL

1. VOLTMETER :

SHOWS THE DISCHARGE VOLTAGE BETWEEN ELECTRODE AND WORKPIECE AND THE STABILITY OF SPARKING.

2. AMMETER :

SHOWS THE DISCHARGE AMPERAGE , AND THE OPERATOR CAN OBSERVE WHETHER THERE IS ANY DIFFERENCE BETWEEN SPARKING AND SETTING AMPERAGE.

3. BUZZER :

IT HAS TWO SOUNDS, THE LOUDEST ONE IS FOR FIRING PROTECTION AND THE OTHER WILL SOUND WHEN SPARKING DEPTH IS REACHED , THE ELECTRODE IN CONTACT WITH THE WORKPIECE ,OR ARCING.

4. DEPTH LAMP :

THE BUZZER WILL SOUND AND THE LAMP LIGHTS WHEN SPARKING DEPTH IS REACHED , AND IT CAN BE STOPPED BY RAISING THE Z-AXIS.

5. EDGE FINDING INDICATOR LAMP:

THE BUZZER WILL SOUND AND THE LAMP LIGHTS WHEN THE ELECTRODE IS IN CONTACT WITH THE WORKPIECE.

6. FIRE CONTROL INDICATOR LAMP:

WHEN THE WORK TANK IS ON FIRE, THE LAMP WILL LIGHT AND THE BUZZER WILL SOUND. THE MACHINE WILL STOP DISCHARGING AT THE SAME TIME.

7. ARC INDICATOR LAMP:

THE LAMP WILL LIGHT AND THE MACHINE WILL PAUSE A FEW SECONDS FOR FLUSHING AWAY DEBRIS WHEN AN ARC OCCURS.

THE MACHINE WILL STOP SPARKING AND THE BUZZER WILL SOUND IF THE ARC SITUATION IS NOT RESOLVED.

8. ARC ADJUST KNOB:

TURN ON THE SWITCH TO START MONITORING FOR ARCS. TURN CLOCKWISE TO INCREASE SENSITIVITY .

9. MONITOR SCREEN:

THE SCREEN OF SKM CONTROLLER.

10. F1-F8 FUNCTION KEYS:

REFER TO CHAPTER 8 FOR DETAILS.

11. NUMERICAL KEYS & ARROW KEYS:

REFER TO CHAPTER 8 FOR DETAILS.

13. DIELECTRIC FLUID PUMP “ON” SWITCH AND LAMP:

PRESS THIS SWITCH FOR FLUSHING DIELECTRIC OIL. FLUSHING WILL STOP WHEN THE “OFF” SWITCH IS PRESSED OR DEPTH REACH.

14. DIELECTRIC FLUID PUMP “OFF” SWITCH AND LAMP:

THE LAMP LIGHTS RED WHEN THE PUMP IS OFF.

15. OVERFLOW CONTROL SWITCH AND LAMP:

WHEN THE SWITCH IS PRESSED THE LAMP WILL COME ON ALLOWING DISCHARGE TO BE SWITCHED ON WITH THE DIELECTRIC LEVEL IS BELLOW THE FLOAT SWITCH.

THE LAMP WILL FLASH IF THE DISCHARGE IS SWITCH IS PRESSED AND THE DIELECTRIC LEVEL IS BELLOW THE FLOAT SWITCH, WHEN THE DIELECTRIC LEVEL REACHES THE FLOAT SWITCH THE LAMP WILL STOP FLASHING AND DISCHARGE WILL COME ON.

16. SYNCHRONOUS FLUSHING CONTROL LAMP.

17. SLEEP SWITCH :

Z-AXIS WILL RISE TO THE MAXIMUM POSITION WHEN THIS SWITCH IS “ON” AND DEPTH IS REACHED.

18. DISCHARGE “ON” SWITCH AND LAMP:

PRESS TO START SPARKING, THE LAMP LIGHTS GREEN.

19. DISCHARGE “OFF” SWITCH AND LAMP.

20. EMERGENCY STOP SWITCH

PRESS THIS SWITCH TO STOP ALL MACHINE FUNCTIONS

21. START SWITCH:

PRESS THIS SWITCH AFTER TURNING THE ISOLATOR ON OR RESETTING THE EMERGENCY STOP SWITCH.

22. DISCHARGE TIMER:

FOR CUMULATE CALCULATION OF SPARKING TIME.

23. X.Y. AXIS SELECTION OF DIRECTION KEY.

24. F1-F8 FUNCTION KEYS.

25. Z-AXIS SPEED CONTROL KNOB:

FOR ADJUSTING THE SPEED OF Z-AXIS UP-DOWN MOVEMENT.

26. Z-AXIS UP SWITCH:

PRESSING THIS SWITCH IN WHEN SPARKING WILL STOP THE MACHINE .

27. Z-AXIS DOWN SWITCH:

CAN NOT BE USED WHEN THE MACHINE IS SPARKING.

28. WORK PIECE ALIGNMENT :

WHEN OPERATOR SET UP THE WORKPIECE, HE CAN USE THE ELECTRODE OR PROBE TO ALIGN THE HORIZONTAL AND VERTICAL WAYS OF WORKPIECE. WHEN THIS SWITCH IS “OFF”, A SHORT CIRCUIT BETWEEN ELECTRODE AND WORKPIECE WILL CAUSE THE MOVEMENT OF THE Z-AXIS TO STOP, PROTECTING THE WORKPIECE, AND THE ALARM BUZZER AND INDICATOR LAMP WILL ACTIVATE.

IF OPERATOR TURNS ON THIS FUNCTION, THE SHORT CIRCUIT DETECTING FUNCTION TURNED OFF. Z-AXIS MOVEMENT WILL BE ALLOWED, THE OPERATOR CAN USE THIS FUNCTION TO ALIGN THE WORK PIECE BY WATCHING THE INDICATING LAMP.

CAUTION:





DUE TO SHORT CIRCUIT PROTECTING FUNCTION BEING “OFF”, THE OPERATOR SHOULD BE CAREFUL TO AVOID CRASHING THE ELECTRODE INTO THE WORKPIECE.

29. JOY KEY:

TO START THE FUNCTION OF NO. 28 AND FUNCTION KEYS-F1-F8.

CHAPTER 7 : DESCRIPTION OF EDM PARAMETER

SKM EDM NC PROVIDES THE FOLLOWING EDM PARAMETERS:

MFD	BP	AP	TA	TB						FA	FB
OFF	0	3	120	3	6	45	3	2	+	OFF	OFF

7-1 MFD (MIRROR FINISHING DISCHARGING)

MFD: SELECTION KEY OF MIRROR FINISHING DISCHARGE WITH THE FOLLOWING 9 DEFAULT VALUES.

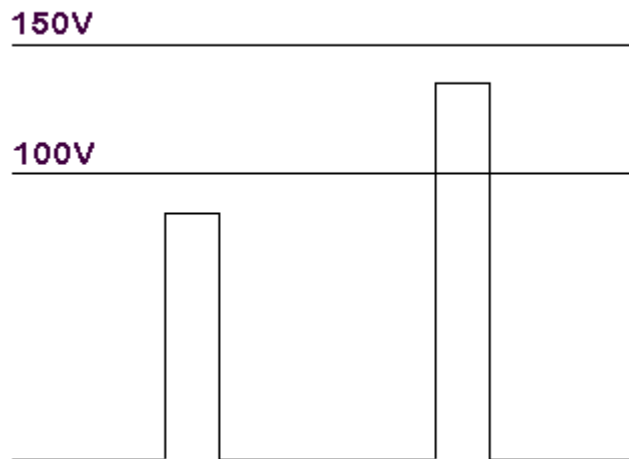
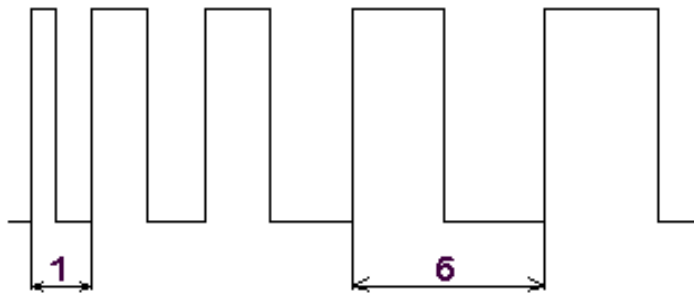

(MFD) SELECTION VS. SURFACE ROUGHNESS

SELECTION	SURFACE ROUGHNESS
1, 2.....	0.10 Raum
3, 4.....	0.13 Raum
5, 6.....	0.16 Raum
7, 8.....	0.20 Raum
9, 10.....	0.23 Raum

IF **MFD** IS SET AS ON(VALUE BETWEEN 1~9) THEN BP, AP, TA, TB WILL BE AUTOMATICALLY SET AS OFF(INACTIVE).

IF **MFD** IS SET AS OFF THEN THE ABOVE VALUES WILL BE RESET TO THEIR ORIGINAL VALUES.

7-2 BP (HIGH VOLTAGE VS. AMPERAGE SWITCH)

BP IS DEFINED AS THE FOLLOWING VALUES BY DEFAULT:

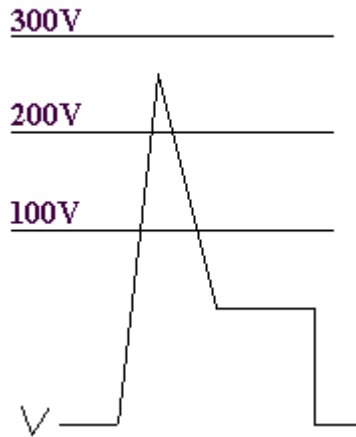

(BP) 260V SELECTION VS. AMPERAGE

SELECTION	AMPERAGE
0.....	0A
1.....	1A
2.....	2A
3.....	3A
4.....	4A
5.....	5A

GENERALLY, BP IS THE SPARKING SPEED TO BE APPLIED IN FINE FINISHING OR ROUGH FINISHING.

IN **FINE FINISHING**, THE SPARKING TIME AND SPARKING DEPTH CAN NOT BE TOO LONG BECAUSE OF THE HIGHER ELECTRODE WEAR WILL BE HAPPEN UNDER THIS CONDITION.

IN **ROUGHING**, BP IS THE IMPORTANT AUXILIARY PARAMETER. USUALLY, WE SET BP AS SECTION 1 OR 2. IT WILL COOPERATE WITH **AP** TO ACCELERATE SPARKING SPEED. THE PERFORMANCE WILL BE INCREASED BY 5~10%; THE ELECTRODE WEAR WILL BE INCREASED BY 1~1.5%.

7-3 AP (LOW VOLTAGE VS. AMPERAGE SWITCH)

AP IS DEFINED AS THE FOLLOWING VALUES BY DEFAULT:

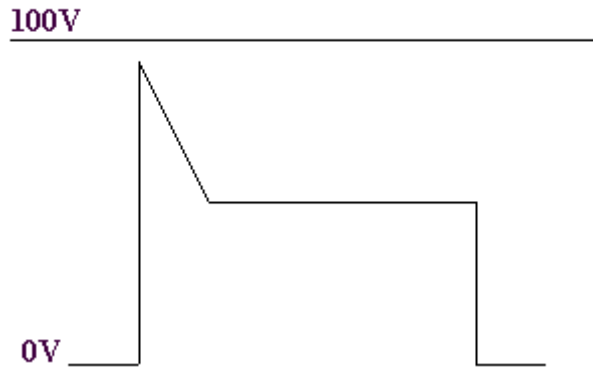

(AP) 90V AMPERAGE STEP VS. AMPERAGE

SELECTION	AMPERAGE	SELECTION	AMPERAGE
1. 5.....	1.5A	15.....	15A
3.....	3A	21.....	21A
4. 5.....	4.5A	30.....	30A
6.....	6A	45.....	45A
9.....	9A	60.....	60A
12.....	12A		

AP CAN BE APPLIED ON FINE AND ROUGH FINISH. THE *CUTTING SPEED*, *ELECTRODE WEARING RATE*, *GAP BETWEEN ELECTRODE AND WORK PIECE* AND *ROUGHNESS* CAN BE DETERMINED BY SETTING THE DIFFERENT COMBINATION OF AP AND TA (SPARKING ON TIME) VALUES. FOR DETAILED INFORMATION, SEE THE REFERENCE ON **APPLICATION NOTE**.

SURFACE / POWER RATIO TABLE

SURFACE AREA	POWER VALUE		REFERENCE
	Cu+ (Electrode) Cuw+ (Electrode)		Gr+ (Electrode) Gr- (Electrode)
0mm ² ~10mm ²	3A~6A		3A~6A
10mm ² ~25mm ²	6A~12A		6A~12A
25mm ² ~100mm ²	12A~21A		12A~21A
100mm ² ~400mm ²	12A~45A		21A~45A
400mm ² ~1600mm ²	21A~60A		45A~60A
1600mm ² ~6400mm ²	21A~60A		60A~120A
6400mm ² Above	21A~60A		120A

7-4 TA (SPARKING ON TIME)

TA IS DEFINED AS THE FOLLOWING VALUES BY DEFAULT:

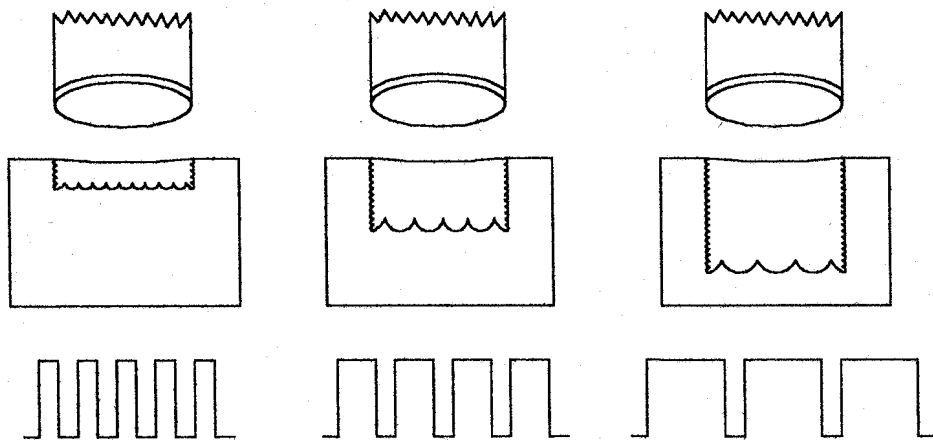
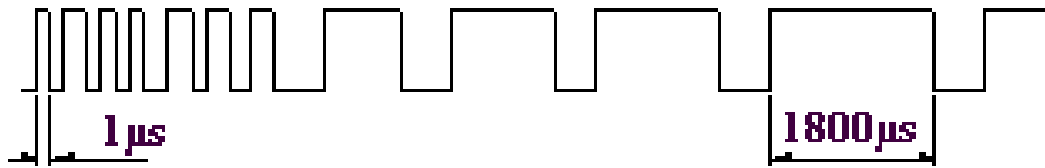

SPARKING ON TIME

1=1 μs	30=30 μs	400=400 μs
2=2 μs	45=45 μs	500= 500 μs
4=4 μs	60=60 μs	600= 600 μs
6=6 μs	90=90 μs	700= 700 μs
8=8 μs	120=120 μs	900= 900 μs
10=10 μs	150=150 μs	1200=1200 μs
15=15 μs	200=200 μs	1500=1500 μs
20=20 μs	300=300 μs	1800=1800 μs

TA IS USED TO CONTROL THE SPARKING ON TIME DURATION. GENERALLY SPEAKING,

1. THE COMBINATION OF **TA** AND **AP** VALUES WILL DETERMINE THE FINISH ROUGHNESS. THE MINIMAL VALUE IS $R_{MAX}6\sim 9\mu M/1\mu S$, MAXIMAL VALUE IS $R_{MAX}90\sim 120\mu M/1800\mu S$.
2. FOR NON-WEARING FINISH, **TA** SHOULD BE SET AS $60\mu S$ OR ABOVE. IF **TA** IS DIRECTLY PROPORTIONAL TO **AP**, THE ELECTRODE WEAR RATE WILL BE LESS. IF **TA** IS SHORT AND **AP** IS LARGE, THE ELECTRODE WEAR RATE WILL INCREASE.
3. SINCE DIFFERENT METALLIC MATERIALS HAVE DIFFERENT CHARACTERISTICS, IT'S NECESSARY TO USE DIFFERENT **TA** SETTING ACCORDING TO THE TABLE DEFINED IN **APPLICATION NOTE**.

THE COMBINATION OF **TA** AND **AP** VALUES WILL DETERMINE THE FINISH ROUGHNESS, ELECTRODE WEAR RATE AND CUTTING SPEED. AS SHOWN ON THE **APPLICATION NOTE**.

HOWEVER, THE OTHER **EDM** CONDITIONS, FOR EXAMPLE, BAD VALUE SETTING OF **TB** (SPARKING OFF TIME), ⚡ SERVO SENSITIVITY, ⚡ SPARKING GAP VOLTAGE, TIMERS CAN CAUSE INSTABILITY, ELECTRODE DAMAGE OR ARCING.

TO AVOID THIS, OUR **NC** CONTROLLER SUPPORTS '**AUTO SETTING**' FUNCTION THAT WILL LOOK FOR THE APPROPRIATE COMBINATION VALUES OF **TB** ⚡ ⚡ BY REFERENCE OF THE SETTING VALUE OF **TA**. THIS FEATURE CAN FIX UP TO 80% OF FINISHING CONDITIONS. HOWEVER, THE USER SHOULD TUNE THE **EDM** CONDITION MANUALLY FOR THE OTHER SPECIAL FINISHES, LIKE *DEEP HOLE*, *BLIND HOLE*, *LARGE AREA* OR *GRADIENT FINISH*.

7-5 TB (SPARKING OFF TIME)

TB IS DEFINED AS THE FOLLOWING VALUES BY DEFAULT:

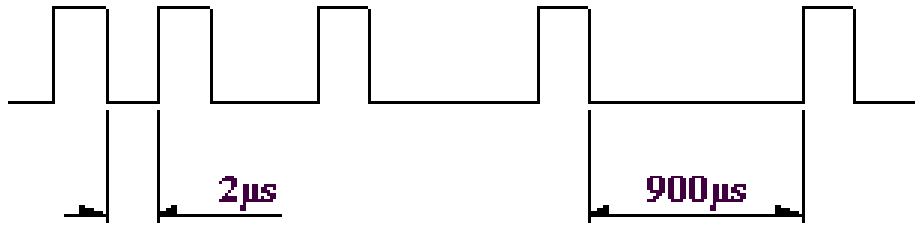

SPARKING OFF TIME

1= 2µs 6=90µs

2= 4µs 7=200µs

3= 8µs 8=450µs

4= 15µs 9=900µs

5= 45µs

$$\text{ACTUAL OFF TIME} = \frac{TA}{8} + TB$$

$$\text{i.e. ACTUAL OFF TIME} = \frac{120}{8} + 2 = 17\mu\text{s}$$

1. **TB** IS THE TIME BETWEEN PULSES OFF TIME WHEN NO IMPACT IONIZATION OCCURS AND DIELECTRIC CONDITIONS ARE RE-ESTABLISHED. USUALLY WHEN THE DISCHARGE IS TABLE AND INTERVAL IS SHORT, EFFICIENCY IS HIGH AND A PROTECTIVE COATING WILL FORM ON THE ELECTRODE. HOWEVER, IT CAUSES POOR CARBON EVACUATION. SO, IT'S NECESSARY TO SET THE APPROPRIATE TIMER VALUES AND DIELECTRIC FLUID FLUSHING POSITION.
2. THE SHORTER OF **TB**, THE HIGHER OF AMPERAGE. THE LONGER OF **TB**, THE LOWER OF AMPERAGE. NO MATTER HOW DIFFERENT **TB** VALUE, THE SPARKING ENERGY ALWAYS BE THE SAME.
3. SINCE DIFFERENT METALLIC MATERIALS HAVE DIFFERENT CHARACTERISTICS, IT'S NECESSARY TO USE DIFFERENT **TB** SETTING TO OBTAIN THE BEST RESULT.
4. UNDER STABLE FINISHING CONDITIONS, THE SPARKING OFF TIME WILL BE THE SAME AS THE **TB** SETTING VALUE. HOWEVER, WHEN AN ABNORMAL SITUATION HAPPENS, FOR EXAMPLE, POOR PERFORMANCE OF CARBON EVACUATION OR ARCING, THE SPARKING OFF TIME WILL BE AUTOMATICALLY PROLONGED UP TO 5 TIMES OF **TB** SETTING VALUE FOR TROUBLE SHOOTING.
5. USER CAN INCREASE THE **TB** VALUE MANUALLY TO BE OF BENEFIT TO THE CARBON EVACUATION WHILE SPARKING IS UNSTABLE. GENERALLY, THIS OPERATION WILL BE APPLIED IN DEEP HOLE, BLIND HOLE OR GRADIENT SPARKING.

6. IF AMPERAGE OF **AP** IS LARGER THAN THE MAXIMUM SETTING VALUE DEFINED IN *SURFACE/POWER RATIO TABLE*, THE USER SHOULD ENLARGE THE **TB** VALUE TO PROTECT ELECTRODE FROM BEING FUSED SINCE HIGH **AP** WILL CAUSE A HIGH TEMPERATURE ON THE ELECTRODE.

7-6 (SERVO SENSITIVITY)

SERVO SENSITIVITY IS DEFINED AS THE FOLLOWING VALUES BY DEFAULT:

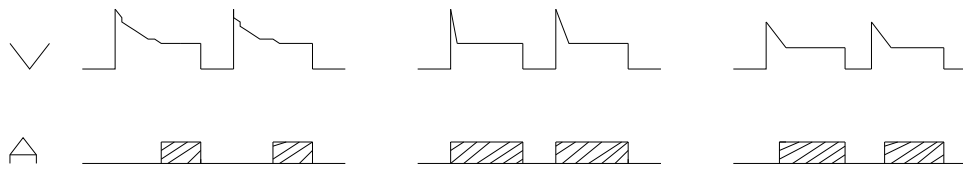

1. SERVO ADJUSTMENT MUST BE SYNCHRONIZED WITH SPARKING ON TIME(TA) AND AMPERAGE (AP). WHEN THE VOLTAGE METER IS STEADY, SYNCHRONIZATION HAS BEEN ACHIEVED.
2. THE SERVO MONITORS THE DISCHARGE GAP DURING DISCHARGE. MAINTAINING THE PROPER GAP IS ONE OF THE MOST IMPORTANT FACTORS IN EDM. SO, WE HAVE VERY CAREFULLY DESIGNED THIS SYSTEM TO ENABLE THE MOST DIFFICULT WORK TO BE PERFORMED.
3. THE WORK HEAD VIBRATION DEPENDS ON THE SERVO SENSITIVITY. THE MORE SERVO SENSITIVITY, THE LARGER THE VIBRATION (RANGE BETWEEN $\pm 0.01\text{MM}$ - 0.025MM). THIS APPROACH IS GOOD FOR CARBON EVACUATION. HOWEVER, THE IMPROPER STRONG SERVO SENSITIVITY WILL DAMAGE ELECTRODE DURING SPARKING. ON THE CONTRARY, WEAK SERVO SENSITIVITY WILL CAUSE THE POOR PERFORMANCE OF CARBON EVACUATION. GENERALLY, STRONG SERVO SENSITIVITY IS APPLIED ON ROUGH FINISHING; WEAK SERVO SENSITIVITY FOR FINE FINISHING.

7-7 ✨ **GAP-V (SPARKING GAP VOLTAGE)**

GAP-V(SPARKING GAP VOLTAGE) IS DEFINED AS THE FOLLOWING VALUES BY DEFAULT:

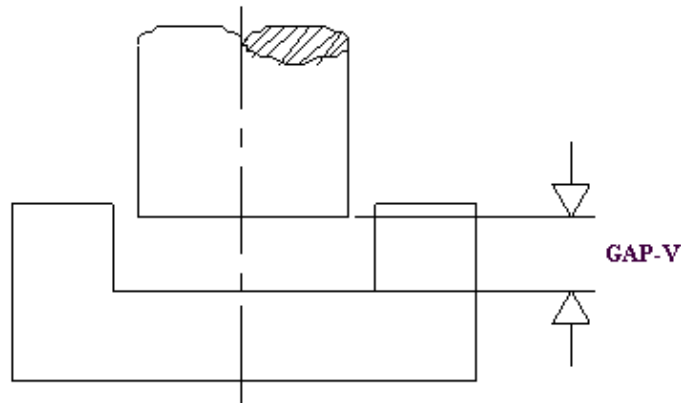

GAP-V(SPARKING GAP VOLTAGE) DETERMINES THE SPARKING DISTANCE BETWEEN ELECTRODE AND WORK PIECE. THE LOWER VALUE OF **GAP-V**, THE CLOSER OF SPARKING DISTANCE, HENCE THE MORE SPARKING ENERGY. IT WILL CAUSE THE SIDE EFFECT OF POOR CARBON EVACUATION PERFORMANCE AND INCREASING THE GAP TEMPERATURE TO MELT THE ELECTRODE.

ON THE OTHER HAND, THE HIGHER VALUE OF **GAP-V**, THE LONGER OF SPARKING DISTANCE, HENCE THE LOWER SPARKING ENERGY. IT'S GOOD FOR CARBON EVACUATION BUT INCREASES THE ELECTRODE WEAR RATE.

1. WHEN THE **GAP-V** VALUE IS SET AS **60V** OR ABOVE, FOR FINE FINISH OR OTHER DIFFICULT MACHINING LIKE DEEP HOLE, BLIND HOLE, LARGE AREA OR GRADIENT FINISH.
2. WHEN THE **GAP-V** VALUE IS SET AS **45V** OR BELOW, THE SPARKING ENERGY IS HIGHER AND ACHIEVES HIGHER EFFICIENCY, FOR ROUGH FINISH. IT SHOULD BE NOTICED THAT THE LOWER VALUE OF **GAP-V** WILL CAUSE HIGHER GAP TEMPERATURE AND MAKE IT EASY TO MELT THE ELECTRODE, THE USER SHOULD BE CAREFUL TO SET THIS PARAMETER WHEN SPARKING A SMALL AREA. MOREOVER, YOU CAN INCREASE THE **TB** VALUE TO INCREASE COOLING TIME TO SOLVE THIS PROBLEM.

7-8 ↑↓ (TIMERS)

↑↓ (TIMERS) IS DEFINED AS THE FOLLOWING VALUES BY DEFAULT:

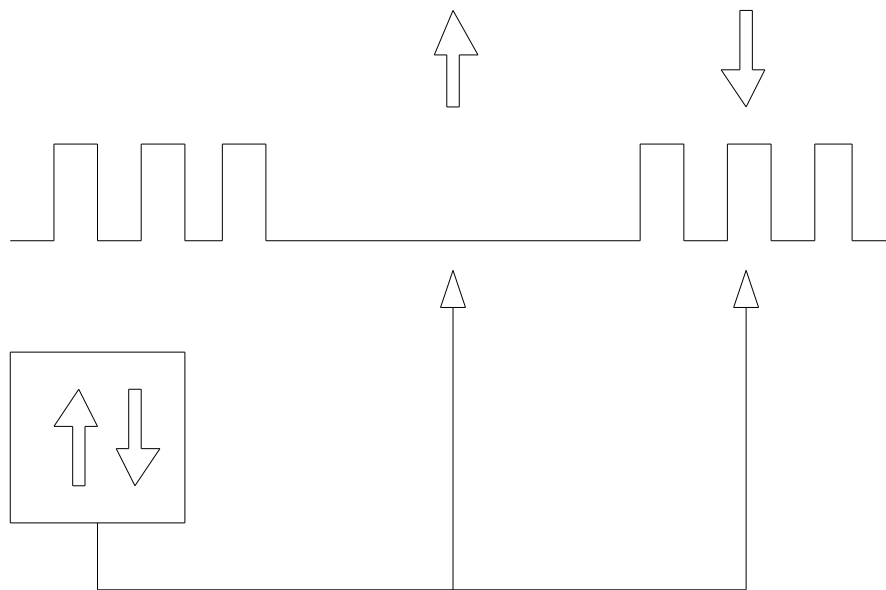

↑↓ (TIMES) ARE USED WHEN IT IS DIFFICULT TO EVACUATE CARBON. LIKE DEEP HOLE OR BLIND HOLD FINISH. THE MOTION OF PUMPING WILL INCREASE THE PERFORMANCE OF CARBON EVACUATION.

FOR GENERAL :

1. WHEN ROUGH FINISHING, BECAUSE THE SPARKING ENERGY IS HIGHER, IT IS EASY TO EVACUATE CARBON. THEREFORE, THE PUMPING FREQUENCY SHOULD BE SET AS LOWER (HIGHER ↓ VALUE AND LOWER ↑ VALUE). ON THE CONTRARY, FOR FINE FINISHING, WE SHOULD SET HIGHER PUMPING FREQUENCY TO INCREASE THE PUMPING PERFORMANCE (LOWER ↓ VALUE).
2. DURING TIMERS UP MOVEMENT, THE SYSTEM WILL AUTOMATICALLY SHUT DOWN SPARKING POWER TO AVOID THE ABNORMAL SIDE SPARKING.

7-9 ELECTRODE POLARITY, DEEP HOLE AND LARGE AREA FUNCTION



ELECTRODE POLARITY

ELECTRODE POLARITY IS TO SET THE POLARITY OF THE ELECTRODE. GENERALLY, A POSITIVE ELECTRODE IS USED TO SPARKING WITH AP THAT IS APPLIED FOR ROUGH AND FINE FINISH; WHEN SPARKING WITH BP ONLY, BOTH OF POSITIVE AND NEGATIVE ELECTRODE ARE SUITABLE. THE ONLY DIFFERENCE IS, A NEGATIVE POLARITY ELECTRODE WILL CAUSE METALLIC POLISH ON WORK PIECE. SOME WORK PIECE MATERIAL REQUIRES A NEGATIVE POLARITY ELECTRODE. PLEASE SEE **APPLICATION NOTE** FOR DETAILED INFORMATION.

FA (DEEP HOLE FUNCTION):

DEEP HOLE MACHINING CAUSES POOR PERFORMANCE OF CARBON EVACUATION AND RETARDS THE PUMPING DOWN MOTION. THE FA FUNCTION IS USED TO FIX THIS PROBLEM. WHEN FA IS ON, IT WILL INCREASE THE ELECTRODE SPEED DOWN TO THE PREVIOUS SPARKING ON POSITION THEN SLOW TO NORMAL SPEED. THEREFORE, IT WILL INCREASE THE EFFICIENCY OF DEEP HOLE FINISH.

FB (LARGE AREA FUNCTION):

LARGE AREA MACHINING CAUSES A VACUUM BETWEEN THE ELECTRODE AND WORLPIECE DURING THE TIMER UP MOTION. THE FB FUNCTION IS USED TO FIX THE PROBLEM. WHEN FB IS ON, IT WILL SLOW DOWN PUMPING MOTION TO ELIMINATE THE VACUUM TUBE BETWEEN ELECTRODE AND WORK PIECE. THEN RESET THE PUMPING MOTION TO NORMAL SPEED.

7-10 BUZZER, DISCHARGE TIMER

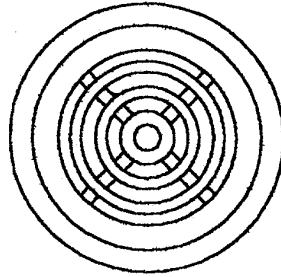

WARNING BUZZER

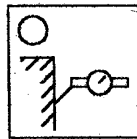

TO TOGGLE THE SWITCH **ON/OFF**, PUSH DOWN THE BUTTON AND **JOY** SWITCH SIMULTANEOUSLY. WHEN IT IS TOGGLED **ON**, THE ELECTRODE WILL NOT BE PROTECTED WHILE COLLIDING WITH WORK PIECE.

IT IS USED FOR THE ELECTRODE ALIGNMENT. USER SHOULD BE CAREFUL WHEN SWITCH ON THIS FUNCTION.

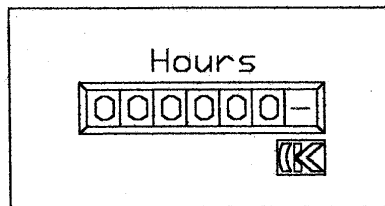

DISCHARGE TIMER

7-11 EMERGENCY STOP, MAIN POWER SWITCH

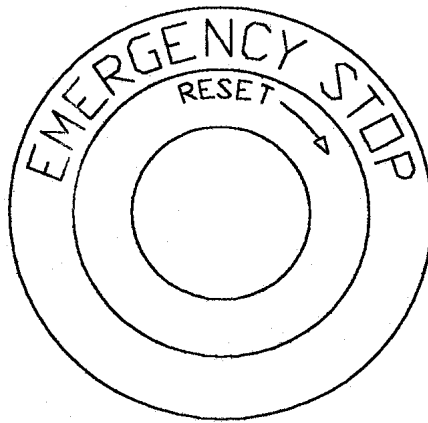

EMERGENCY STOP SWITCH

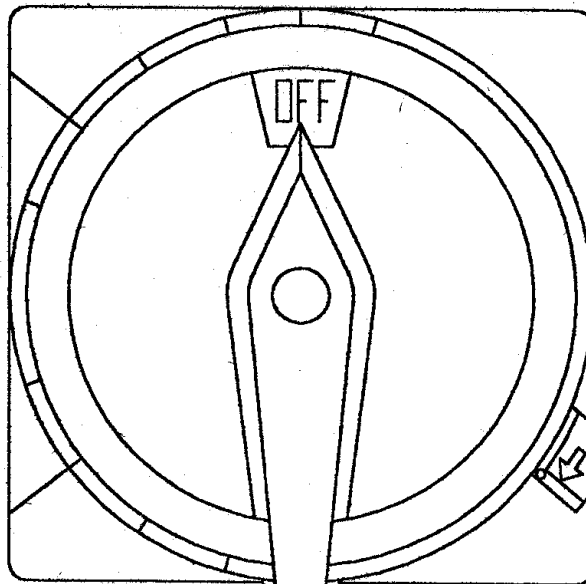

MAIN POWER SWITCH

7-12 LIGHTING SYSTEM AND FIRE GUARD INDICATOR

1. ILLUSTRATION:

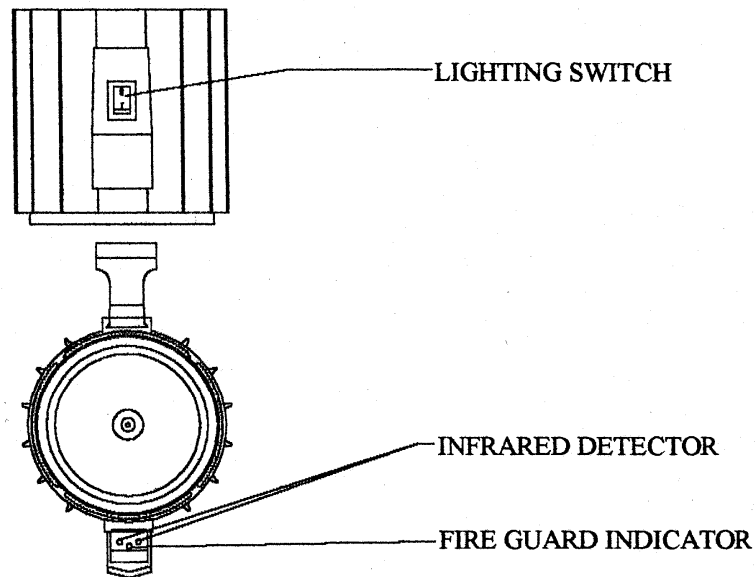

2. DESCRIPTION:

1> ACTIVATE LIGHTING SYSTEM:

- a. TURN ON LIGHTING SWITCH.
- b. THE FIRE GUARD FUNCTION WILL BECOME INVALID AND EXTINGUISH THE FIRE GUARD INDICATOR, THEREFORE, THE USER HAS TO TURN OFF THE LIGHTING SWITCH WHEN HE IS NOT AROUND THE WORK PLACE.

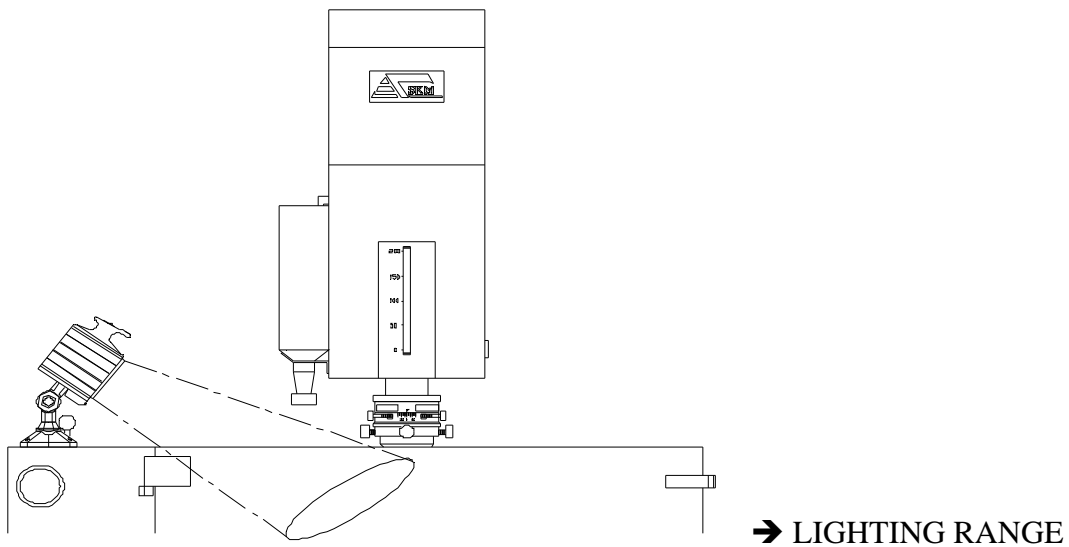

2> ACTIVATE FIRE GUARD:

- a. TURN OFF LIGHTING SWITCH TO EXTINGUISH WORKING LIGHT.
- b. THE FIRE GUARD FUNCTION WILL BECOME VALID AND THE INDICATOR WILL BE ON. WHEN THE FIRE GUARD IS ACTIVATED, IT STARTS TO MONITOR DURING SPARKING. IT WILL SHUT DOWN THE SYSTEM POWER AND GIVE A BEEP WARNING WHEN FLUID TEMPERATURE TOO HIGH OR A FIRE ON WORKING PLATFORM.
- c. THE FIRE EXTINGUISHER SHOULD BE CHECKED ONCE A YEAR AND IT CAN BE USED ONLY ONE TIME, AND FOR THE REPLACEMENT, PLEASE REFER TO **SAFE GUIDE** CHAPTER 1-7 FOR DETAILS. NOTICE THE EXPIRE DATE OF FIRE EXTINGUISHER AND CHECK THE PRESSURE GAUGE EVERYDAY. IF THE PRESSURE IS TOO LOW, PLEASE REFILL. THE MACHINE CAN BE OPERATED **ONLY ACCOMPANIED WITH THE FIRE EXTINGUISHER.**

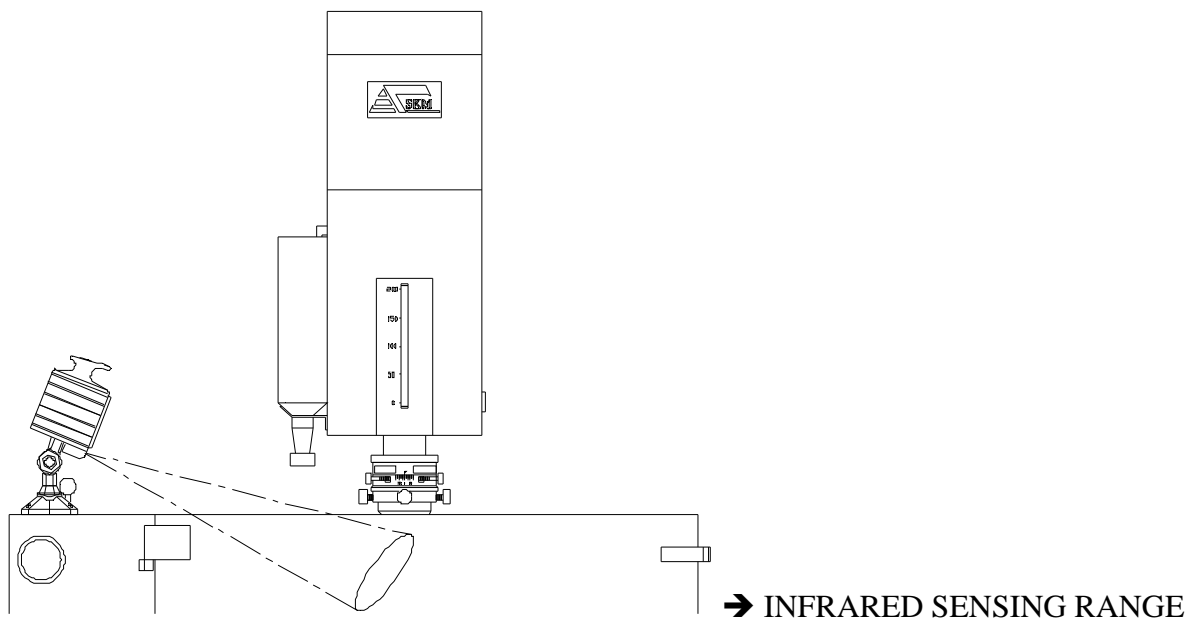

NOTE:

THE FIRE GUARD DETECTS THE FIRE SOURCE BY AN INFRARED SENSOR. TO AVOID FALSE FIRE ALARM HAPPENING, THE MACHINE SHOULD NOT BE DIRECTLY LOCATED UNDER SUNLIGHT, BULB OR OTHER HEAT LIGHT SOURCE. WE STRONG RECOMMEND INSTALLING OUR MACHINE UNDER A COLD LIGHT SOURCE SUCH AS FLUORESCENT LIGHTING.

CONCERNING THE FIRE PREVENTION, PLEASE REFER TO SAFE GUIDE CHAPTER 1-5.

CHAPTER 8 : THE SYSTEM OPERATION AND APPLICATION

8-1 SYSTEM APPLICATION

SPECIFICATION OF FUNCTION KEYS & SWITCHES

1. FUNCTION KEY F1-F10 : PROVIDE MANY DIFFERENT FUNCTIONS OF THE SKM CONTROLLER.
2. NUMERICAL KEYS 0-9 ,+ / - , . : FOR SETTING NUMBERS, i.e.; X.Y.Z AXIS VALUE SETTING, FINISHING SIZE, OR DISCHARGE TIME SETTING.
3. CURSOR KEY $\leftarrow \rightarrow \uparrow \downarrow$: $\uparrow \downarrow$ KEYS FOR CHOOSING DIFFERENT COORDINATES (UP, DOWN, POSITIVE, NEGATIVE), - SUCH AS - ABSOLUTE & INCREMENTAL VALUE SETTING OR FOR PROGRAMMING. $\leftarrow \rightarrow$ KEY ARE FOR SPARKING CONDITIONS SETTING, SUCH AS : MFD,BP,AP,TA,TB, $\frac{\text{M}}{\text{S}}$, $\frac{\text{M}}{\text{S}}$,,, \downarrow , FA, FB, AND SETTING A PROGRAM.
4. YES, NO, ENT, KEY: FOR ANSWERING SELECTION, ENT KEY IS FOR RECONFIRMING AND ENTERING YOUR ANSWER.
5. DEL, \leftarrow KEY : DEL KEY NOT USED, AND \leftarrow KEY IS THE SAME AS “BACKSPACE” KEY .



三 貴 機 械 有 限 公 司
SANE KUEI MACHINERY CO.,LTD.

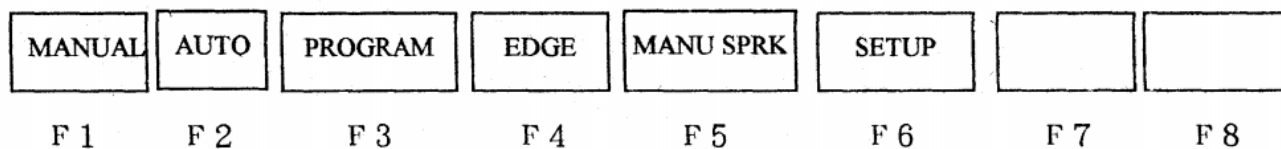

8-1

THIS MAIN SCREEN (FIG. 8-1) PROVIDES THE FOLLOWING FUNCTIONS :

1. F1 - MANUAL MOVEMENT
2. F2 - AUTO MOVEMENT
3. F3 - PROGRAM
4. F4 - EDGE FINDING
5. F5 - MANUAL SPARKING
6. F6 - PARAMETER SETTING

8-2 MANUAL MOVEMENT

PRESS THE F1 FUNCTION KEY AT THE MAIN MENU (FIG. 8-1), AND THE SCREEN WILL DISPLAY AS BELOW (FIG.8-2) :

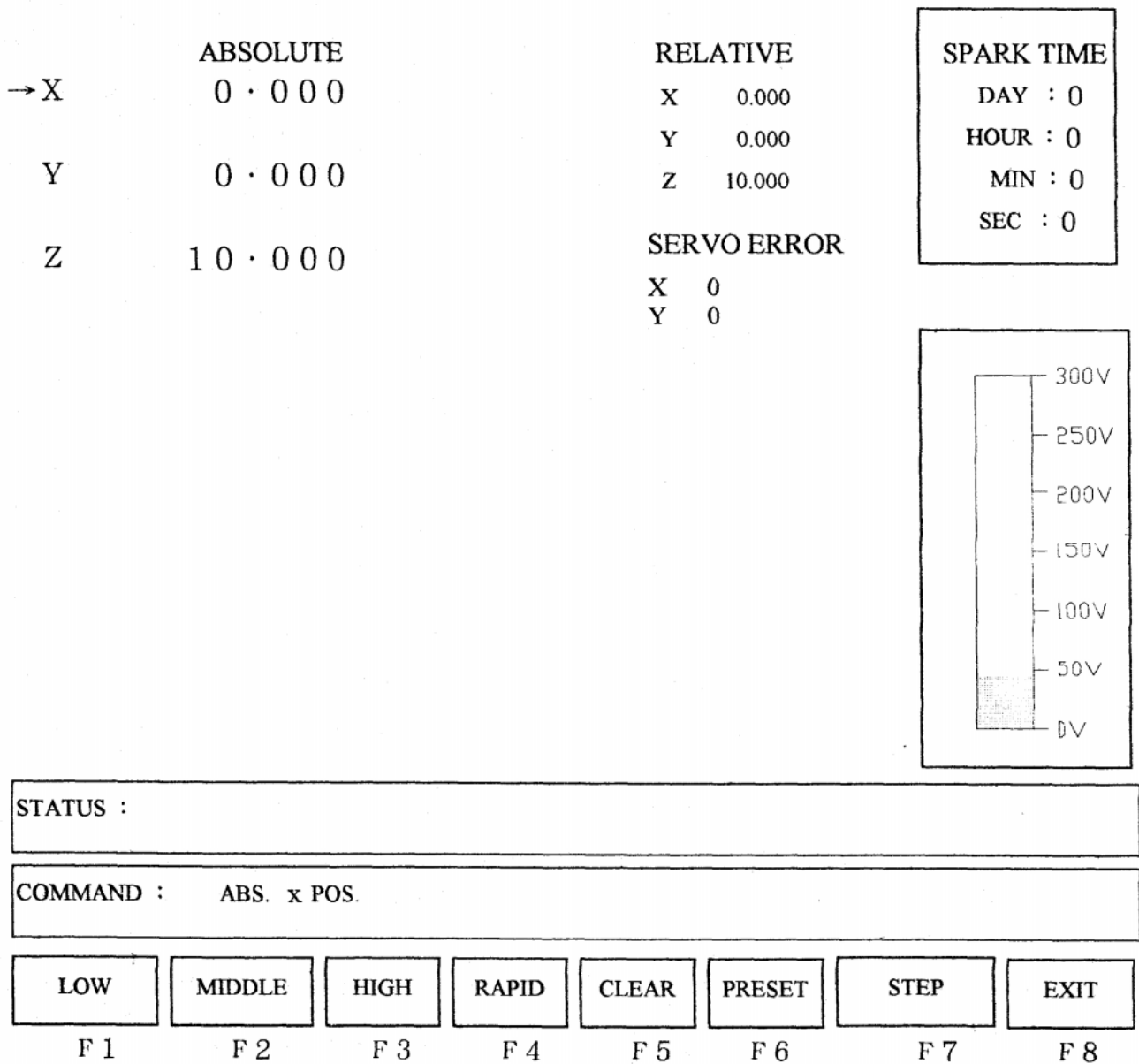

8-2

1. F1-F4 SPEED SELECTION KEY, F7 STEP MOVEMENT:

MANUAL MOVEMENT IS THE MOST USEFUL FOR SETTING WORKPIECE AND ELECTRODE.

THERE ARE TWO KINDS OF MANUAL MOVEMENT, CONTINUOUS MOVEMENT AND STEP MOVEMENT.

THE STEP MOVEMENT RANGE IS : 1MM, 0.1MM,0.01MM,0.001MM

UNDER MANUAL MOVEMENT THE USER CAN CHOOSE DIRECTION BY PRESSING X+, X-, Y+, Y- ON THE HAND BOX (REMOTE CONTROL PANEL).

2. F5 : CLEAR

FOR CLEARING THE PRESENT VALUE TO ZERO. THE SCREEN WILL SHOW A COMMAND LINE AS BELOW:

ABS. X POS. CLEAR (YES/NO) =

PRESS “YES” AND “ENTER” KEY TO CONFIRM, THEN THE INDICATED VALUE OF AXIS WILL BE CLEAR.

PRESS “NO” AND “ENTER” KEYS TO ESCAPE, THEN GIVE UP THIS FUNCTION OF F5.

3. F6 : SET PARAMETER

FOR PRESENTING THE VALUE OF POSITION WHICH THE ARROW KEY IS LOCATED, THE SCREEN WILL SHOW A COMMAND LINE AS BELOW.

ABS. X POS. SET =

WHEN YOU SET UP ANY NUMERICAL KEY AND PRESS “ENTER” ,THE X-AXIS WILL SHOW THE NUMBER YOU SET.

4. F8 : EXIT

PRESS F8 THE SYSTEM WILL RETURN TO MAIN MENU ,AND THE FUNCTION OF MANUAL MOVEMENT WILL BE GIVEN UP.

8-3 AUTO MOVEMENT

PRESS THE F2 FUNCTION KEY AT THE MAIN MENU (FIG. 8-1), AND THE SCREEN WILL DISPLAY AS BELOW (FIG.8-3) :

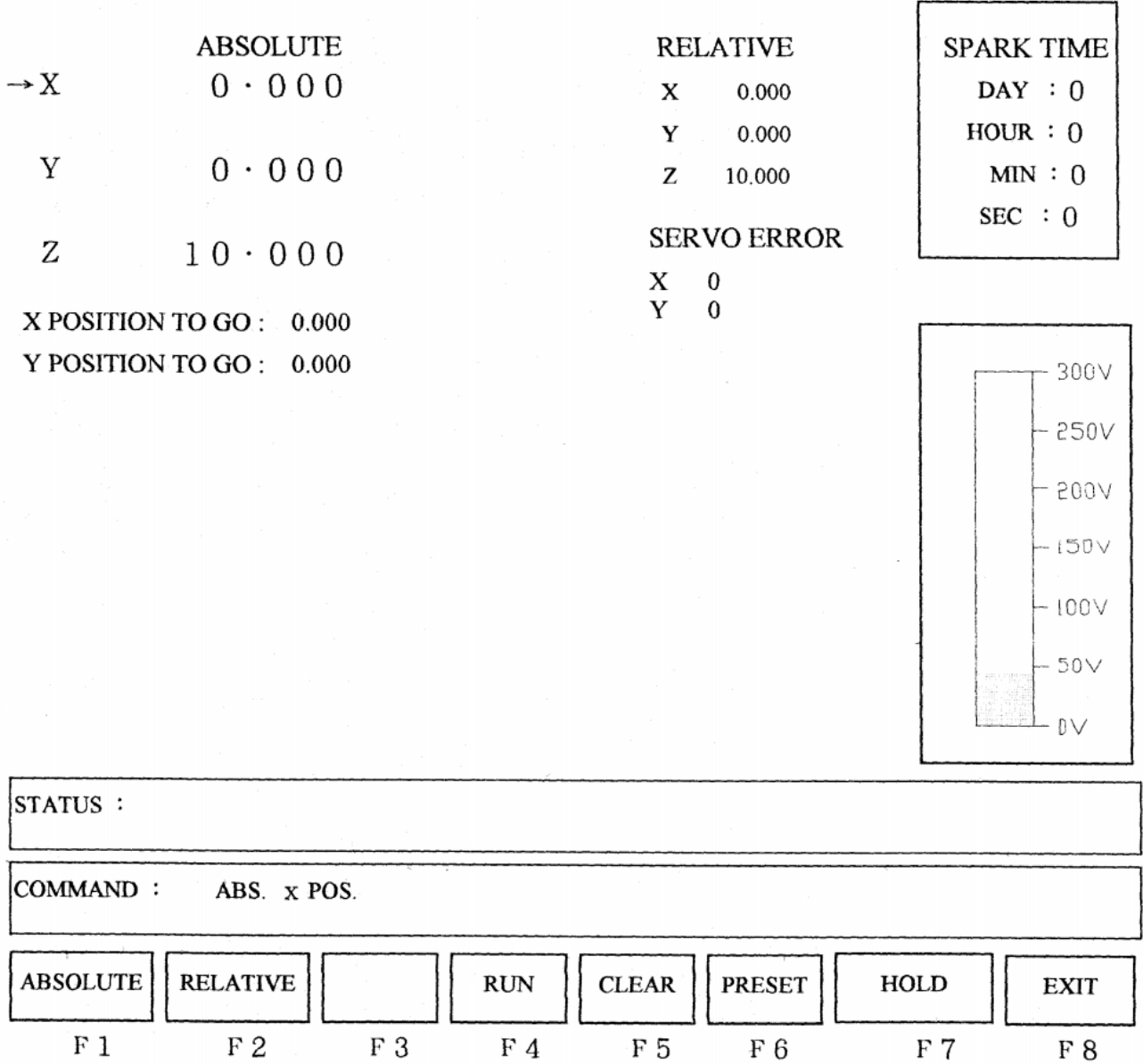

AUTO MOVEMENT OF THE X-AND Y-AXIS.

1. F1 ABSOLUTE VALUE:

INPUT VALUE FOR ABSOLUTE COORDINATE MOVEMENT. THERE IS AN ARROW KEY SHOWING IN FRONT OF X POSITION AND ALSO A QUESTION DISPLAY IN THE COMMAND INPUT LINE.

TARGET X POS. =

KEY IN THE TARGET POSITION OF THE X-AXIS MOVEMENT, AND BY MOVING THE “**↑↓**” KEY TO THE “Y” LINE AND THERE IS A QUESTION DISPLAY IN THE COMMAND INPUT LINE.

TARGET Y POS. =

KEY IN THE TARGET POSITION OF Y-AXIS MOVEMENT. THEN PRESS F4 KEY TO RUN . THE WORKTABLE WILL MOVE TO THE INDICATED POSITION AUTOMATICALLY

2. F2 RELATIVE VALUE:

INPUT FOR RELATIVE COORDINATE MOVEMENT. THE METHOD OF INPUT AND FUNCTION ARE THE SAME AS WITH F1 ABSOLUTE VALUE.

3. F4 RUN:

TO RUN THE AUTO MOVEMENT PROGRAM

4. F5 CLEAR:

THE SAME WITH F5 FUNCTION KEY OF FIG. 8-2.

5. F6 PRESET :

THE SAME WITH F6 FUNCTION KEY OF FIG. 8-2.

6. F7 HOLD:

THE OPERATOR CAN HOLD THE AUTO MOVEMENT PROGRAM BY PRESSING F7 KEY . PRESS F7 KEY , THE MACHINE WILL STOP AUTO MOVEMENT. AND PRESS F7 AGAIN, THE MACHINE WILL RE-START MOVEMENT.

7. F8 EXIT :

8. RETURN TO THE MAIN MENU (FIG. 8-1).

8-4 EDGE FINDING

PRESS THE F4 FUNCTION KEY AT THE MAIN MENU (FIG. 8-1), AND THE SCREEN WILL DISPLAY AS BELOW (FIG.8-4A) :

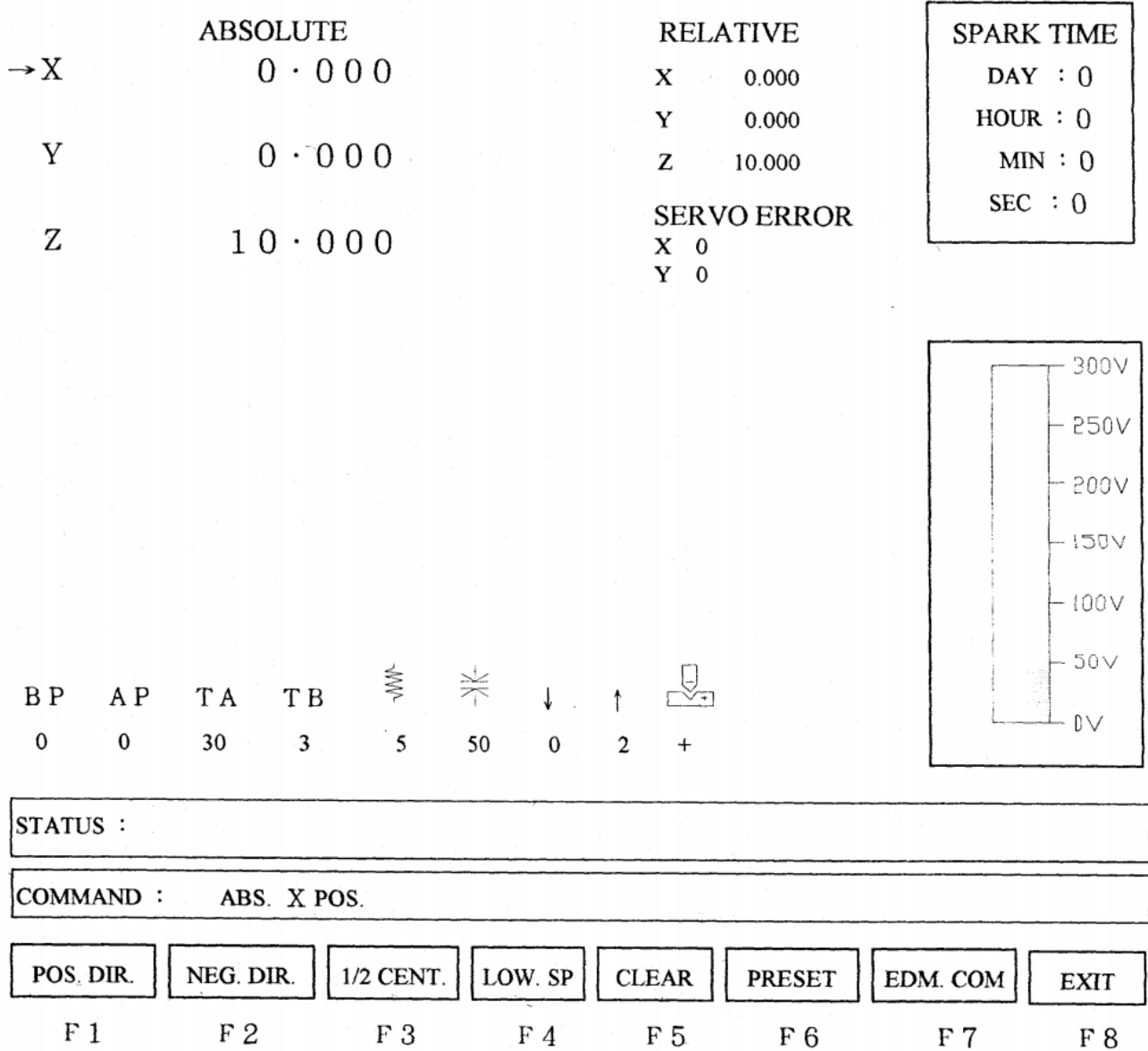

8-4A

THIS MACHINE PROVIDES X-,Y-AXIS AUTO FINDING EDGE,

THE OPERATOR CAN USE THE “**↑↓**” KEY TO SELECT X- OR Y- AXIS FOR EDGE FINDING AND PRESS F1 KEY TO POSITIVE AUTO EDGE FIND OR F2 TO NEGATIVE AUTO EDGE FIND.

1. F1 POS. DIR. :

THE DIRECTION OF EDGE FINDING IS POSITIVE .

2. F2 NEG. DIR. :

THE DIRECTION OF EDGE FINDING IS NEGATIVE.

3. F3 1/2 CENT :

USE THE ARROW KEYS TO INDICATE THE AXIS WHICH YOU WANT, THEN PRESS F3 AND THE INDICATED VALUE OF AXIS WILL BE CALCULATED TO HALF VALUE. THE COMMAND LINE WILL SHOW.

X HALF VALUE (YES/NO) =

PRESS “YES” AND “ENTER” KEY TO CONFIRM, THEN THE INDICATED VALUE OF AXIS WILL BE HALVED
PRESS “NO” AND “ENTER” KEY TO ESCAPE AND GIVE UP THE FUNCTION OF F3.

4. F5 CLEAR :

THE SAME WITH F5 FUNCTION OF FIG. 8-1.

5. F6 PRESET :

THE SAME WITH F6 FUNCTION OF FIG. 8-1.

6. F7 EDM. COM :

PRESET SPARKING CONDITION DATA. THE SCREEN WILL BE CHANGED TO FIG. 8-4B FROM FIG. 8-4A
AFTER PRESSING F7 KEY:

(4) F7 PRESET SPARKING CONDITION DATA :

PRESET SPARKING CONDITION DATA. THE SCREEN IS AS BELOW AFTER PRESSING F7 KEY:

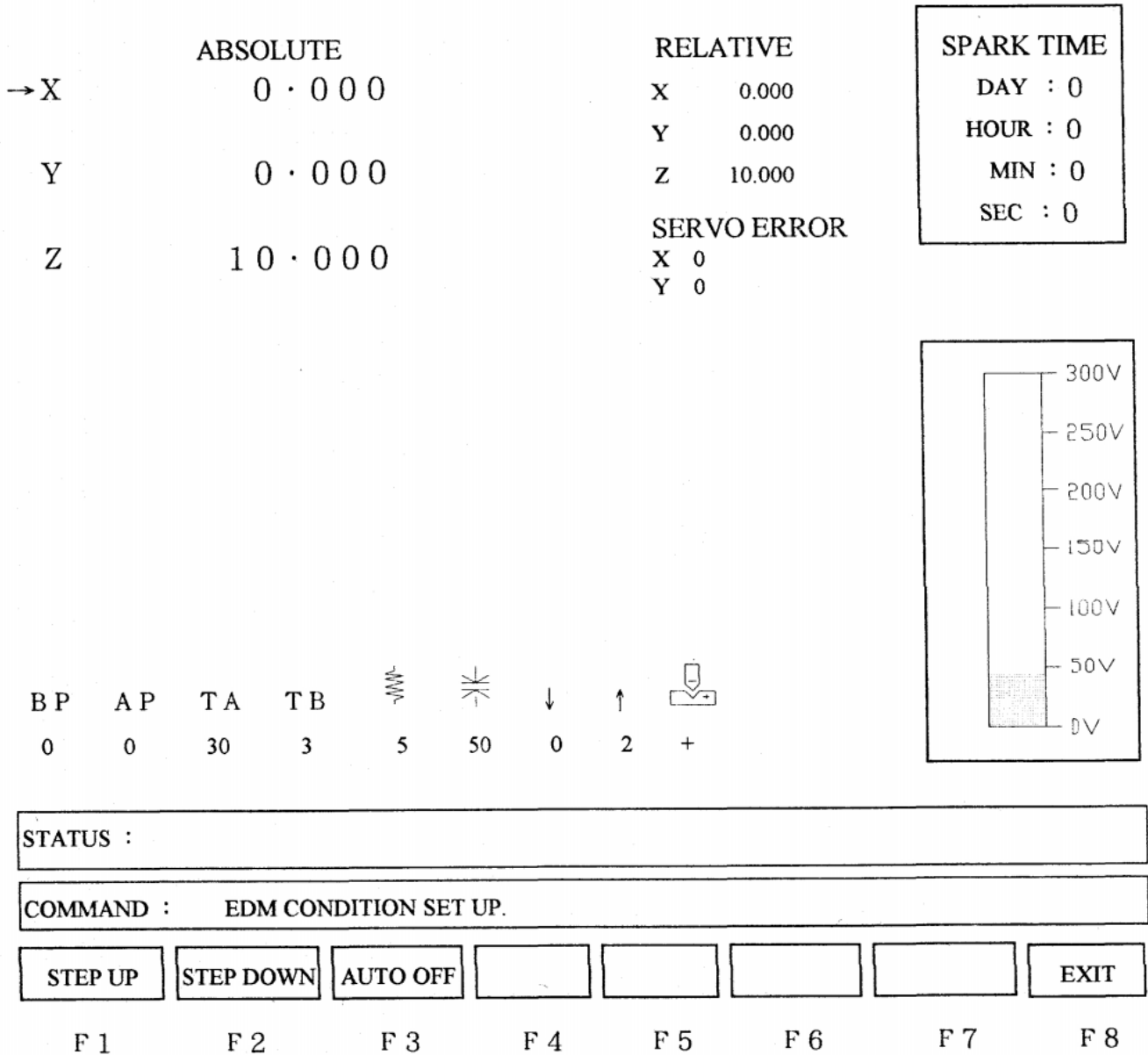

8-4B

THE SPARKING CONDITIONS ARE AS BELOW ON THE SCREEN :

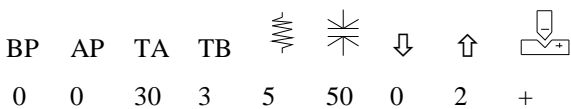

THERE IS A BLINKING BLOCK UNDER THE “BP” POSITION WHICH THE OPERATOR CAN MOVE BY PRESSING “ ← → ” KEY TO CHOOSE THE CONDITION REQUIRED, THEN SELECT THE FOLLOWING KEYS .

A. F1 - STEP UP F2 - STEP DOWN : THESE 2 KEYS ARE FOR FINDING EDGE OF Z-AXIS ONLY.

WHEN SPARKING ON SWITCH IS PRESSED, THE SYSTEM WILL USE THIS CONDITIONS TO EXECUTE EDGE FINDING OR SPARKING. CAUTION : AT THIS SCREEN, THE SPARKING DEPTH CAN'T BE CONTROLLED. IF YOU WANT TO CONTROL THE Z DEPTH, YOU SHOULD RETURN TO MANUAL SPARKING SCREEN.

B. F8 - EXIT :

WHEN PRESS F8 THE SYSTEM WILL RETURN TO MAIN MENU, THE EDGE FINDING FUNCTION WILL BE CANCELED.

C. F9 - CLEARING THE SPARKING TIMER SETTING.

8-5 MANUAL SPARKING

MANUAL SPARKING IS THE MOST SIMPLE AND EFFICIENT MODE. TO COMPLETE A SINGLE CAVITY. IN THIS MODE IT IS ONLY NECESSARY TO PRESET THE Z-AXIS DEPTH AND SPARKING CONDITION DATA.

HERE IS THE SCREEN (FIG. 8-5A) AFTER PRESSING F5 KEY OF MAIN MENU (FIG. 8-1).

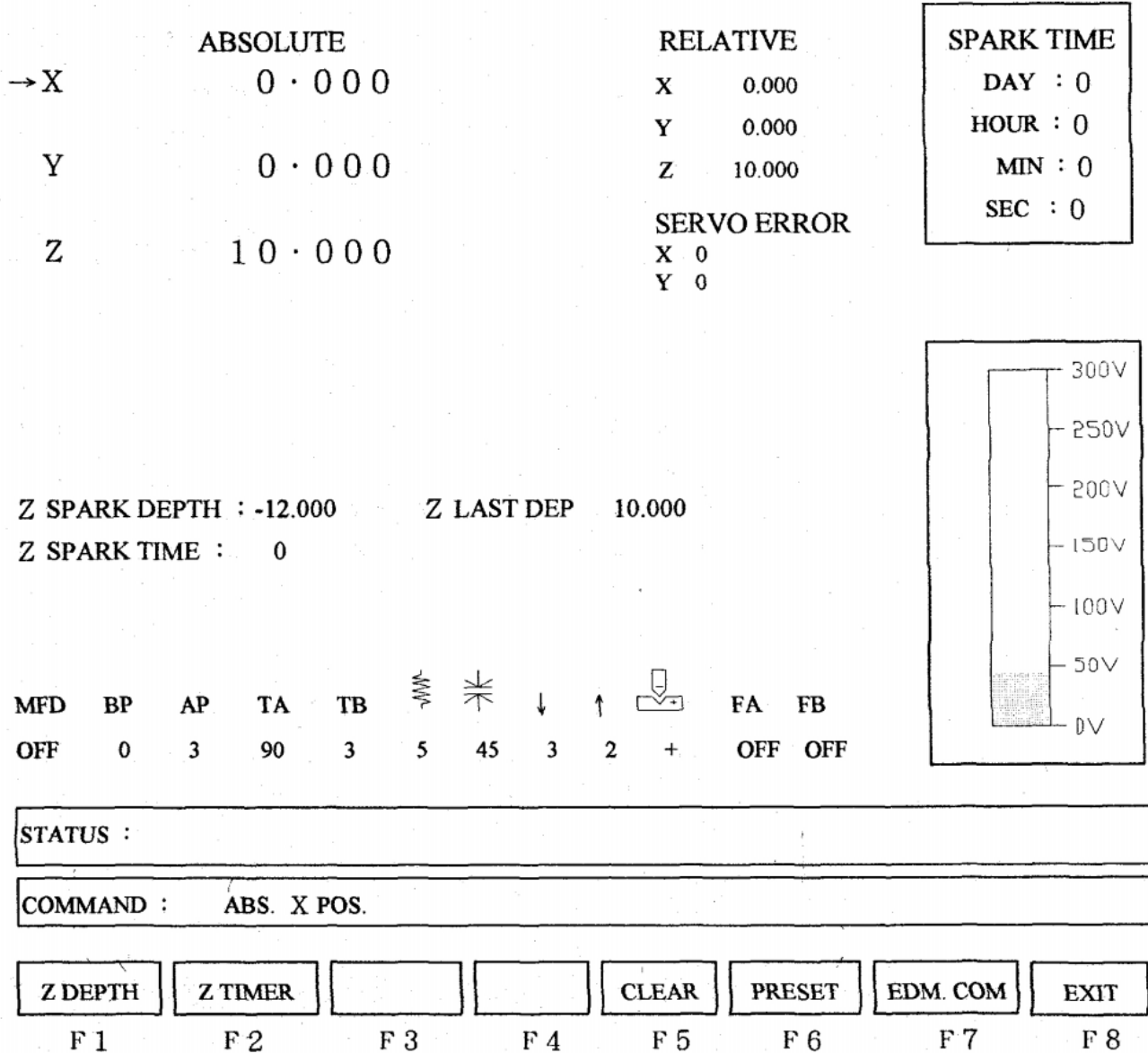

8-5A

THIS SCREEN, FIG. 8-5A NOT ONLY CAN PROVIDE ALL OF THE SPARKING CONDITIONS ,COORDINATES VOLTAGE AND SPARKING TIMER, IT ALSO SHOWS THE FOLLOWING INFORMATION FOR EASY OPERATION.

Z SPARK DEPTH : SHOWS THE PRESENT DEPTH OF Z-AXIS.

Z SPARK TIMER : TO PRESET THE SPARKING TIME.

Z LAST DEP : SHOWS THE LASTING DEPTH OF Z-AXIS.

AFTER FINDING THE REFERENCE VALUE OF Z-AXIS (BY EDGE FINDING PROCESS), THE OPERATOR CAN PRESS F1 (TO PRESET THE Z AXIS DEPTH) , AND THE SCREEN WILL DISPLAY AS BELOW:

SET Z SPARK DEPTH =

PRESET THE DEPTH USING THE NUMERICAL KEYS, AND PRESET THE SPARKING TIMER BY PRESSING F2 KEY IF NECESSARY.

SET Z SPARK TIMER =

REMARK:

THE MACHINE WILL STOP SPARKING WHEN EITHER THE DEPTH OR TIMER IS REACHED, AND THE BUZZER WILL SOUND.

EX : SETTING THE SPARKING TO 5 MM AND SPARKING TIME TO 60 MIN. WHEN THE SPARKING ON SWITCH IS PRESSED. THE SYSTEM WILL DETECT THE Z DEPTH AND SPARKING TIME. IF ANY ONE OF THESE CONDITIONS ARE REACHED. THE SYSTEM WILL STOP SPARKING AND GIVE A FINISH SIGNAL TO OPERATOR.

PRESS F7 (SPARKING CONDITIONS) KEY BEFORE DISCHARGING, AND THE SCREEN (AS FIG. 8-3B) WILL DISPLAY AS BELOW:

→ X ABSOLUTE
 0.000

Y 0.000

Z 10.000

RELATIVE
X 0.000
Y 0.000
Z 10.000

SPARK TIME
DAY : 0
HOUR : 0
MIN : 0
SEC : 0

Z SPARK DEPTH : -12.000 Z LAST DEP 10.000
Z SPARK TIME : 0

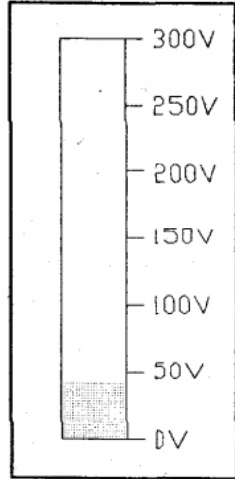

MFD BP AP TA TB ↓ ↑ FA FB
OFF 0 3 90 3 5 45 3 2 + OFF OFF

STATUS :

COMMAND : ABS. X POS.

SET UP	SET DOWN	AUTO DFF					EXIT
F 1	F 2	F 3	F 4	F 5	F 6	F 7	F 8

8-5B

MOVE THE FLASHING CURSOR TO THE DESIRED CONDITION, THEN USE THE F1 OR F2 KEY TO STEP UP OR DOWN THE VALUE (PLEASE REFER TO CHAPTER 7 FOR DETAILS OF THE FUNCTION KEYS)

MFD BP AP TA TB ↓ ↑ FA FB
OFF 0 3 120 3 6 45 3 2 + OFF OFF

REMARK :

THE OPERATOR CAN MODIFY THE SPARKING CONDITIONS DURING SPARKING.

THE MANUAL SPARKING SCREEN ALSO PROVIDES FUNCTIONS F5 & F6, TO CLEAR OR PRESET THE COORDINATES. THIS IS MORE CONVENIENT FOR MULTI-HOLES MACHINING.

WHEN THE USER CHANGES THE SPARKING CONDITIONS, THE F3 AUTO TUNING OFF FUNCTION PROVIDES THE ABILITY TO LOCK OUT THE SPARKING CONDITIONS.

8-6 PROGRAMMING

THE PROGRAM EDITING SCREEN IS SIMILAR TO THE MANUAL SPARKING SCREEN , BUT IT CAN MAKE PROGRAMS FOR MULTI-CAVITY, FINE FINISH WITH NO LIMIT TO THE NUMBER OF PROGRAM BLOCKS. THE SCREEN (FIG. 8-4A) IS AS BELOW AFTER PRESSING F3 KEY OF THE MAIN MENU:

	PROGRAM	LISTING		
FILE NAME		SIZE	TIME	DATE
→ P1		156	11:57:12	4, 24, 1996

STATUS :

COMMAND :

INSERT	EARSE	EDIT		RUN	PAGE DOWN	PAGE UP	EXIT
F 1	F 2	F 3	F 4	F 5	F 6	F 7	F 8

8-6A

THE INSTRUCTIONS OF FUNCTION KEYS-F1-F8 OF PROGRAM SYSTEM (FIG.8-6A) ARE BELOW:

1. F1 - INSERT :

TO INSERT A NEW PROGRAM, ALL THE FILES WILL BE NAMED BY P----(USING NUMERICAL KEYS WITH A MAXIMUM NUMBER OF 8 DIGITS) TO SAVE ON THE DISK.

AFTER PRESSING F1 KEY ,THE INPUT LINE WILL SHOW:

INSERT FILE NAME = P

USE NUMERICAL KEYS AND “ENT” KEY TO CONFIRM PROGRAM NAME . USE F3 EDIT FUNCTION TO EDIT THIS PROGRAM.(REFER TO THE PROCESS OF F3 KEY), OTHERWISE. THE SCREEN WILL ONLY SHOW “0”.

2. F2 - ERASE :

USE THE “ ↑ ↓ ” ARROW KEY TO SELECT THE PROGRAM WHICH YOU WANT TO DELETE, AND PRESS F2, AT THIS MOMENT THERE ARE SOME QUESTION IN STATUS LINE.

FILE NAME P-----

FILE DELETED Y/N=

THIS PROGRAM WILL BE DELETED AFTER PRESSING “YES” AND “ENT” KEY, OTHERWISE, THIS FUNCTION WILL BE CANCELED.

3. F3 - EDIT :

FOR EDITING A PROGRAM IN THE LIST. USE THE ARROW KEYS TO SELECT THE PROGRAM THAT YOU WISH TO EDIT, AND PRESS F3 , THEN THE SCREEN (FIG. 8-6B) IS AS BELOW:

PROGRAM NAME : P1

N0:	XPOS	YPOS	Z-DEPTH	A/R	MFD	BP	AP	TA	TB			↓	↑		FA	FB
→ 1	0.000	0.000	-5	ABS	___	0	6	200	4	7	45	4	3	+	OFF	OFF
2	10.000	0.000	-5	ABS	___	0	6	200	4	7	45	4	3	+	OFF	OFF
3	20.000	0.000	-5	ABS	___	0	6	200	4	7	45	4	3	+	OFF	OFF
END																

STATUS :

COMMAND :

INSERT	ERASE	EDIT	PAGE DOWN	PAGE UP		RUN BLK	EXIT
F 1	F 2	F 3	F 4	F 5	F 6	F 7	F 8

8-6B

N0:	XPOS	YPOS	Z-DEPTH	A/R	MFD	BP	AP	TA	TB			↓	↓		FA	FB
-----	------	------	---------	-----	-----	----	----	----	----	--	--	---	---	--	----	----

8-6C

FUNCTION KEYS OF PROGRAM EDITOR (REFER TO FIG. 8-6B) :

F1 - INSERT LINE :

INSERT A BLOCK LINE INTO PROGRAM . THIS KEY CAN ONLY COPY THE LINE WHERE THE ARROW KEY IS LOCATED, THERE IS NO LIMIT TO INSERT LINES. THIS FUNCTION IS ONLY FOR INSERT NOT FOR EDIT. PRESS F3 TO EDIT PROGRAM BLOCK.

2. F2 - DELETE A BLOCK LINE AT THE CURSOR.

3. F3 - EDIT LINE :

MODIFY AND EDIT A LINE. I.E.: THERE ARE 5 BLOCK PROGRAMS ON FIG. 8-4B , WHEN YOU PRESS F3, THE SYSTEM WILL ENTER INTO THE EDIT MODE, IN THE EDIT LINE FUNCTION, YOU CAN EDIT THE Z-DEPTH AND SPARKING CONDITIONS, THE DETAILS AS EXPLAINED IN THE FOLLOWING:

FOR EX.: ON FIG. 8-4B

THE PROGRAM HAS BEEN CREATED WITH 5 BLOCKS, THE OPERATOR CAN PRESS F3 TO EDIT ONE BLOCK, THE SCREEN WILL CHANGE FROM FIG. 8-6B TO FIG. 8-6D. AT THE LEFT SIDE OF SCREEN OF 8-4D, THERE IS A FLASHING CURSOR WHICH IS THE BLOCK EDIT INDICATOR, IT MEANS THAT THE MARKABLE AREA CAN BE EDITED BY USER. THE OPERATOR CAN USE THE CURSOR- UP/DOWN LEFT/RIGHT TO MOVE THE CURSOR TO THE DESIRED EDIT AREA.

4. F4 - DOWN PAGE :

OPERATOR CAN SEE THE PROGRAM ON THE NEXT PAGE BY PRESSING F4

5. F5 - UP PAGE :

OPERATOR CAN SEE THE PROGRAM ON THE PREVIOUS PAGE BY PRESSING F5



6. F7 - EXECUTION FROM MIDDLE BLOCK:

WHEN THE PROGRAM EXECUTION IS STOPPED, YOU CAN RESTART THE PROGRAM FROM A SPECIFIC BLOCK.

MOVE THE ARROW KEY TO THE PROGRAM BLOCK (UNDER THE SCREEN OF 8-6B) WHICH YOU REQUIRE AND PRESS F7 ,THIS RETURNS YOU TO THE SCREEN OF 8-6A AND PRESS F5.

THE MACHINE WILL START TO DISCHARGE FROM THE PROGRAM BLOCK WHICH YOU SELECTED.

PROGRAM NAME : P1

N0:	XPOS	YPOS	Z-DEPTH	A/R	MFD	BP	AP	TA	TB			↓	↑		FA	FB
→ 1	0.000	0.000	-5	ABS	---	0	6	200	4	7	45	4	3	+	OFF	OFF
2	10.000	0.000	-5	ABS	---	0	6	200	4	7	45	4	3	+	OFF	OFF
3	20.000	0.000	-5	ABS	---	0	6	200	4	7	45	4	3	+	OFF	OFF
END																

STATUS : THIS IS NEW FILE

COMMAND : PLEASE USE INSERT KEY TO INSERT BLOCK

SET UP	SET DOWN	AUTO OFF	PAGE DOWN	PAGE UP		Z TIMER	EXIT
F 1	F 2	F 3	F 4	F 5	F 6	F 7	F 8

8-6D

IN LINE EDIT MODE, WHEN CURSOR IS MOVED TO THE SYSTEM AREA THE FUNCTION KEYS WILL CHANGE TO THE FOLLOWING.

(1) F1 (STEP UP OR A/R)

WHEN THE CURSOR MOVES TO THE CONDITIONS ITEM, F1 STEPS UP EDM CONDITION VALUE BY 1

(2) F2 (DECREASE 1 DEGREE) : STEP DOWN

THE SAME AS F1 EXCEPT IT DECREASES THE EDM SETTING VALUE BY 1.

(3) F3 (SET AS UNAVAILABLE FOR AUTO-MATCHING) :

PRESS F3 TO SET CURRENT SELECTED EDM VALUE AS UNAVAILABLE FOR AUTO- MATCHING FUNCTION.

(4) F4 (NEXT PAGE) :

TO NEXT PAGE.

(5) F5 (PREVIOUS PAGE) :

TO PREVIOUS PAGE.

(6) F7 (SETTING SPARKING TIME) :

PRESS F7 TO SET THE SPARKING TIME WHICH APPLIES TO Z-DEPTH FINISHING. AFTER F7 PRESSED, THERE IS A ‘ ’ SIGN AND A EDIT STRING SHOWING ON THE EDIT CELL AS THE FOLLOWING:

Z-SPARKING TIMER =

WHEN THE SPARKING TIMER VALUE BEEN SET, THE EDIT CELL WILL SHOW ANOTHER EDIT STRING OF ‘Z-DEPTH’ FOLLOWED BY *SIGN. THIS IS FOR CHECKING WHETHER TO ISSUE A COMMAND FOR SPARKING TIME CONTROL OR NOT. IF YOU WANT TO CANCEL THE SPARKING TIMER SETTING, PRESS F7 AGAIN THEN FOLLOW AN ENTER KEY.

4. RUNNING PROGRAM

THERE ARE TWO WAYS TO RUN A PROGRAM. FIRST, RUNNING FROM FIRST THE BLOCK TO THE END. SECOND, RUNNING FROM A SELECTED BLOCK TO THE END (MIDDLE RUN).

(1) RUNNING FROM FIRST BLOCK TO THE END

FIG 8-4A, MOVE ↑ ↓ KEY TO SELECT A DESIRED FILE NAME THEN PRESS F5 KEY TO RUN THIS PROGRAM. THE PROGRAM WILL BE TRIGGERED TO RUN FROM THE FIRST BLOCK TO THE END BLOCK. BEFORE PRESSING F5, THE USER SHOULD TURN THE OIL SWITCH ON TO FILL OIL TO TANK, WHEN EVERYTHING IS READY, PRESS F5 AND THE SCREEN WILL SHOW AS FIG 8-6E TO RUN. IT IS NOT NECESSARY TO PRESS SPARKING “ON” SWITCH .

→ X ABSOLUTE
 0 · 000

Y 0 · 000

Z 10 · 000

RELATIVE
X 0.000
Y 0.000
Z 10.000

SERVO ERROR
X 0
Y 0

SPARK TIME
DAY : 0
HOUR : 0
MIN : 0
SEC : 0

X POSITION TO GO : 0.000
Y POSITION TO GO : 0.000

Z SPARK DEPTH : -5.000 Z LAST DEP 10.000
Z SPARK TIME : 0

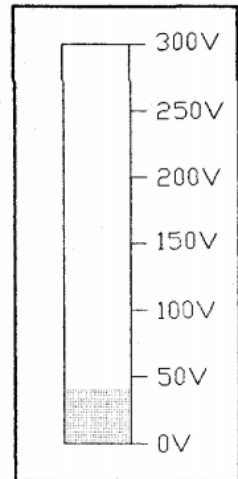

MFD	BP	AP	TA	TB			↓	↑		FA	FB
0	0	6	200	4	7	45	4	3	+	OFF	OFF

STATUS :

COMMAND : ABS. X POS.

SET UP	SET DOWN	AUTO OFF	STOP	CONTINUE			EXIT
F 1	F 2	F 3	F 4	F 5	F 6	F 7	F 8

8-6E

(2) SECOND, RUNNING FROM A SELECTED BLOCK TO THE END

FIG 8-4A, MOVE ↑ ↓ KEY TO SELECT A DESIRED FILE NAME THEN PRESS F3 KEY TO ENTER EDIT MODE SHOWN ON FIG 8-4B. THE USER CAN SELECT A DESIRED BLOCK BY ↑ ↓ KEY. THE USER CAN TAG THE MIDDLE RUN PROGRAM COMMAND BY PRESSING F7 THEN PRESS F8 BACK TO FIG 8-4A THEN PRESS F5 TO RUN CURRENT SELECTED BLOCK TO THE END BLOCK.

WHEN A PROGRAM IS RUNNING, THE USER CAN MODIFY THE EDM PARAMETERS. HOWEVER, THE CONTENTS OF PROGRAM WILL NOT BE MODIFIED.

PRESS F8 TO INTERRUPT THE PROGRAM RUNNING. THE PROGRAM WILL PAUSE AND SHOW A SYSTEM PROMPT MESSAGE:

STOP RUNNING, BACK TO MAIN MENU(Y OR N)=

IF THE USER PRESSES THE YES KEY FOLLOWED BY THE ENT KEY TO CONFIRM, THE PROGRAM WILL STOP RUNNING. OTHERWISE, PRESS THE NO KEY FOLLOWED BY THE ENT KEY TO CONFIRM, THE PROGRAM WILL CONTINUE RUNNING.

WHEN A PROGRAM IS RUNNING, THE USER CAN PRESS F10 TO TOGGLE BETWEEN 1. THE EDM TIME COUNTER AND 2. THE RUNNING PROGRAM NAME AND CURRENT BLOCK ID ON THE UP-RIGHT CORNER OF THE PAGE

8-7 PARAMETER SETTING

ON MAIN MENU, PRESS F6 TO ENTER PARAMETER SETTING MODE. SHOWN AS FIG. 5-1.

MACHINE PARAMETER SETTING:

LINEAR SCALE READ OUT DIRECTION (0=-.1=+):

-AXIS 0.000

-AXIS 0.000

-AXIS 0.000

LINEAR SCALE READ OUT PULSE RESOLUTION (μm):

-AXIS 5.000

-AXIS 5.000

-AXIS 5.000

LINEAR SCALE LENGTH CORRECTION (0~+-99.9 μm):

-AXIS 0.000

-AXIS 0.000

-AXIS 0.000

STATUS:							
COMMAND: X-AXIS =							
*Up	*Down	Page	Save				Exit
F 1	F 2	F 3	F 4	F 5	F 6	F 7	F 8

FIG. 8-7

MACHINE PARAMETER SETTINGS ITEMS SHOWN AS THE FOLLOWING:

1. F1 UP

MOVE UP TO PREVIOUS ITEM.

2. F2 DOWN

MOVE DOWN TO NEXT ITEM.

3. F3 PAGE

TO LOOK UP NEXT PAGE OF PARAMETER SETTING ITEMS.

4. F4 SAVE:

SAVES THE MODIFIED PARAMETERS TO SYSTEM. SOME ITEMS (SHOWN ON THE FOLLOWING WITH # SIGN) CANNOT BE SAVED BY USER DIRECTLY, SYSTEM WILL PROMPT FOR A PASSWORD THESE SETTINGS CAN BE ACCESSED BY MANUFACTURER. THE OTHER ITEMS CAN BE SAVED WITHOUT PASSWORD VERIFICATION.

(1) LINEAR SCALE READ OUT DIRECTION (0=-,1=+): *

SETTING THE DIRECTION OF X, Y AND Z-AXIS MOVEMENT.

(2) LINEAR SCALE READ OUT PULSE RESOLUTION (μm):*

SETTING THE SCALE READ OUT PULSE RESOLUTION.

(3) LINEAR SCALE LENGTH CORRECTION ($0\pm 99.9\mu\text{m}/100\text{mm}$):*

SETTING THE VALUE OF LINEAR SCALE LENGTH CORRECTION .

(4) Z-AXIS HEIGHT WHILE XY MOVING (mm)

SETTING THE Z-UP POSITION WHILE THE ELECTRODE IS WAITING FOR BLOCK CHANGE OR Z-UP POSITION OF THE END OF THE PROGRAM .

(5) DISPLAY UNIT (mm=0, INCH=1)

SETTING THE UNIT OF COORDINATE VALUE.

(6) CNC CONTROL SYSTEM INSTALL (1=CNC, 0=NC) :*

SETTING THE PLATFORM IS BASED ON ZNC OR CNC.

(7) AT CURRENT RANGE (30A=0, 45A=1, 60A=2, 90A=3) :*

SETTING THE MAXIMUM CURRENT OF AT .

(8) XY POSITION SPEED (mm/min) :

NOT AVAILABLE FOR ZNC.

(9) LANGUAGE INSTALL (0=ENGLISH, 1=CHINESE) :

SETTING ACTIVE LANGUAGE.

(11) X AXIS POSITION GAIN (1~10)

X AXIS = 1.000

(12) Y AXIS POSITION GAIN (1~10)

Y AXIS = 1.000

(13) X AXIS BACKLASH COMPENSATION (MM)

X AXIS = 0.000



(14) Y AXIS BACKLASH COMPENSATION (MM)

Y AXIS = 0.000

(15) MOTOR ACCEDE TIME CONSTANT (MSEC)

TIME = 32.000

8-8 FINE FINISH ADJUSTMENT OF SKM EDM

	BP	AP	TA	TB				 (V)
1	0	30	700	3	3	5	7	45
2	0	21	600	3	3	5	7	45
3	0	15	500	3	3	5	7	45
4	0	12	400	3	3	4	6	45
5	0	9	300	3	3	4	6	45
6	0	6	200	3	3	4	6	45
7	0	4.5	150	3	3	4	6	45
8	0	4.5	90	3	3	*3	6	45
9	0	4.5	45	3	3	*2	6	45
10	0	4.5	20	3	2	*2	6	50
11	1	4.5	10	2	2	*1	5	50
12	0	3	120	3	3	*3	5	45
13	0	3	60	3	3	*3	5	45
14	0	3	30	3	2	*2	5	50
15	0	3	10	2	2	*1	5	50
16	0	3	4	2	2	*1	5	50
17	0	1.5	15	2	2	*1	5	50
18	0	1.5	8	2	2	*1	5	50
19	0	1.5	4	2	2	*1	5	60
20	2	0	15	2	2	*1	5	*120
21	2	0	8	2	2	*1	5	*120
22	1	0	2	1	2	*1	5	*120

- (1) POSITION 1-7 ARE FOR ROUGH FINISH AND BEAR THE LOWEST WEAR RATE.
- (2) POSITION 8-11 ARE FOR FINE FINISH OF A LARGE AREA.
- (3) POSITION 12-22 ARE FINE FINISH OF A SMALL AREA.
- (4) I.E.: YOU CAN SPARK BEGINNING FROM POSITION 6, AND THEN SETTING THE FOLLOWING PROGRAM FROM POSITION 7, 12, 14, 22 IN SEQUENCE FOR FINE FINISH.

THE FORMULA OF FINISHING DISCHARGE DEPTH :

THE FINISHING DISCHARGE DEPTH = THE TOTAL DIFFERENCE BETWEEN THE INTENDED AND THE PRESENT VALUE OF AP PLUS TA VALUE.

FOR EXAMPLE :

THE MACHINING CONDITION FROM AP=15A , TA=400us CHANGE TO AP=9A , TA=200us FROM FIGURE A , THEN THE FINISHING DISCHARGE DEPTH IS :

AP		TA	
0.06mm	0.05mm	0.025mm	0.025mm
15A → 12A → 9A		400 → 300 → 200	

FROM ABOVE :

AP FROM 15A TO 12A TO 9A, THE NECESSARY DEPTH ARE $0.06 + 0.05 = 0.11\text{mm}$, TA FROM 400 TO 300 TO 200, THE NECESSARY DEPTH IS $0.025 + 0.025 = 0.05\text{mm}$. THE TOTAL DEPTH AP + TA = $0.11\text{mm} + 0.05\text{mm} = 0.16\text{mm}$.

SO WHEN THE MACHINING CONDITION FROM AP15ATA400us, CHANGE TO AP9ATA200us, THE MINIMUM MACHINING DEPTH OF Z AXIS IS ABOUT **0.16mm**.

FIG. A

THE DEPTH SETTING OF AP POSITION DIFFERENCE		THE DEPTH SETTING OF TA POSITION DIFFERENCE	
60A		1800	60
↓	0.2mm	↓	0.04mm
45A		1500	45
↓	0.15mm	↓	0.04mm
30A		1200	30
↓	0.1mm	↓	0.04mm
21A		900	20
↓	0.08mm	↓	0.03mm
15A		700	15
↓	0.06mm	↓	0.03mm
12A		600	10
↓	0.05mm	↓	0.03mm
9A		500	8
↓	0.03mm	↓	0.03mm
6A		400	6
↓	0.03mm	↓	0.025mm
4.5A		300	4
↓	0.02mm	↓	0.025mm
3A		200	2
↓	0.01mm	↓	0.025mm
1.5A		150	1
↓	0.01mm	↓	0.02mm
BP		120	
1 2		↓	0.02mm
↓	0.005mm	90	
1		↓	0.02mm

CHAPTER 9 : MAINTENANCE

DISMANTLING PROCEDURE OF THE POWER SUPPLY UNIT IS :

TURN OFF THE MAIN SWITCH TO THE “OFF” POSITION AND REMOVE ALL OF THE SCREWS ON THE CABINET.

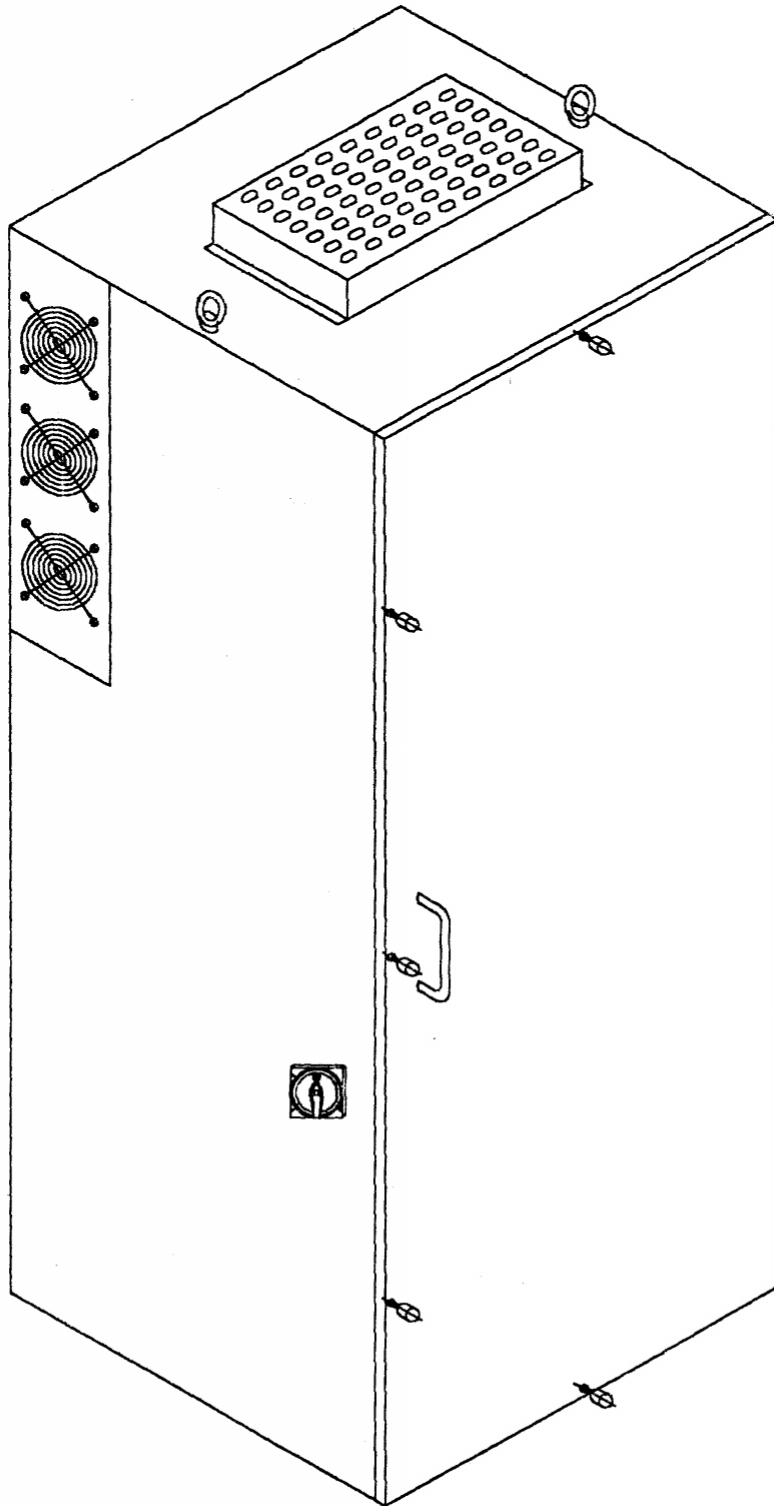

FIG 9-1

THERE ARE SOME POSSIBLE PROBLEMS AFTER TURNING ON THE POWER SUPPLY(MAIN) SWITCH.

SITUATION 1: INDICATOR LIGHTS DO NOT WORK.

MAINTENANCE ACTION:

1. CHECK IF THE VOLTAGE COMPLIES WITH LOCAL REQUIREMENTS?

FOR EX. 3 AC 220V IS FOR TAIWAN.

2. CHECK (FIG. 9-2) IF THE NO-FUSE-BREAKER (NFB) OF CONTROLLER NO.1 POSITION HAS TRIPPED?

IF “YES”, RESET IT.

3. CHECK (FIG. 9-2) IF THE 10A NFB OF CONTROLLER NO.2 POSITION HAS TRIPPED?

IF “YES”, RESET IT.

3. CHECK (FIG. 9-2) IF THE 2.5A NFB OF CONTROLLER NO.5 POSITION HAS TRIPPED?

IF “YES”, RESET IT.

3. CHECK (FIG. 9-2) IF THE 3A NFB OF CONTROLLER NO.6 POSITION HAS TRIPPED?

IF “YES”, RESET IT.

SITUATION 2: PUMP DOES NOT WORK.

ACTION:

1. CHECK IF THE VOLTAGE COMPLIES WITH THE LOCAL REQUIREMENT?

FOR EX. 3 PHASE/220V IS FOR TAIWAN.

2. CHECK (FIG. 9-2) IF THE PUMP MAGNETIC & OVER LOAD SWITCH OF CONTROLLER NO.3 POSITION HAS TRIPPED?

IF “YES”, PRESS THE RESET SWITCH.

SITUATION 3 : NO DISPLAY ON THE MONITOR SCREEN.

ACTION:

3. CHECK IF THE 2.5A NFB OF CONTROLLER NO. 7 POSITION (FIG. OF PAGE 69) HAS TRIPPED?

IF “YES”, RESET IT.

SITUATION 4: WORK HEAD DOES NOT MOVE UP OR DOWN.

ACTION :

1. PUSH DISCHARGE SWITCH ON AND OFF FOR 2 TIMES CONTINUOUSLY.
2. CHECK IF Z-AXIS TRAVEL IS OUT OF THE WORK PIECE?

IF “YES”, TURN OFF THE MAIN SWITCH AND ADJUST Z-AXIS TO SUITABLE TRAVEL.

SITUATION 5 : THE LIGHT DOES NOT WORK.

ACTION:

3. CHECK (FIG. 9-2) IF THE 10A NFB OF CONTROLLER NO. 4 POSITION HAS TRIPPED?

IF “YES”, RESET IT.

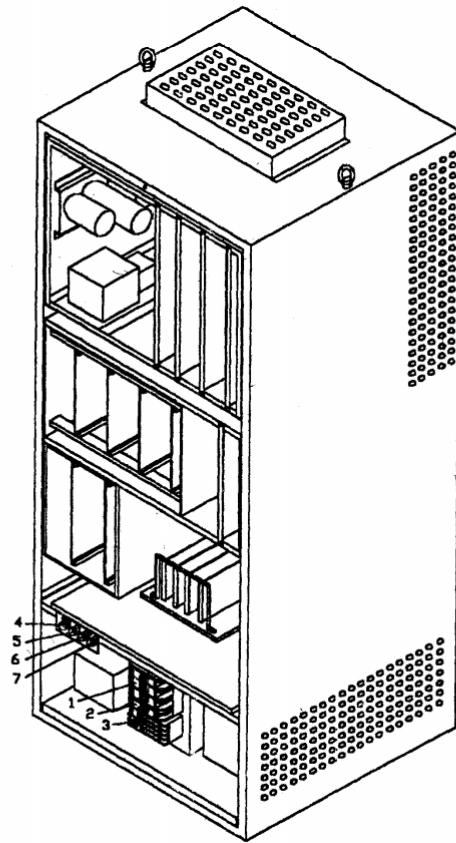
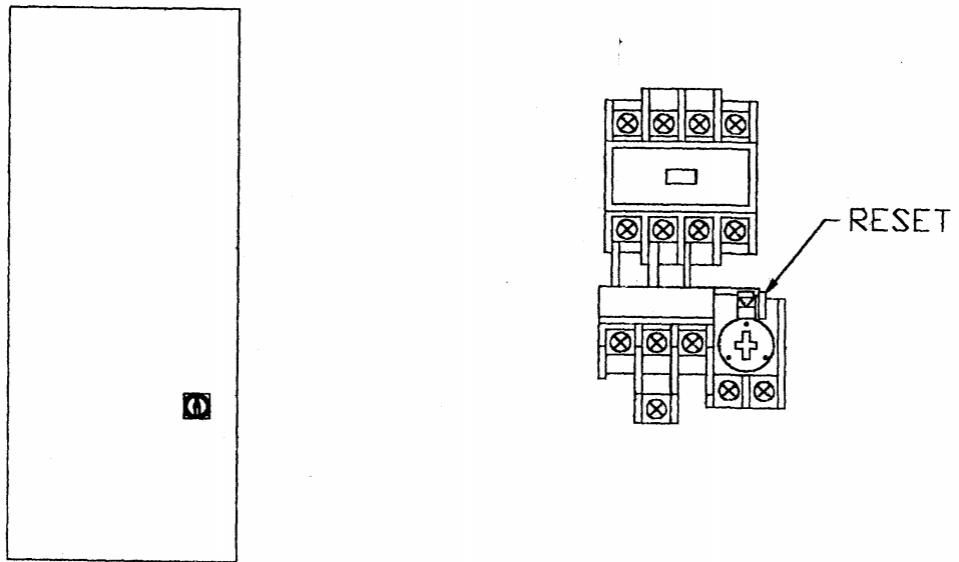

FIG 9-2



SAFETY GUIDE

1-1.: DEFINITION OF RISKS

1-2: BASIC PRECAUTIONS

1-3: ENVIRONMENTAL CONDITIONS

1-4: INSTRUCTIONS RELATING TO HEALTH

1-5: FIRE PREVENTION

1-6: INSPECTION

1-7: REPLACEMENT & SERVICING INTERVALS

1-8: WARNING LABELS

1-9: CONFIGURATION OF MACHINE AND OPERATION POSITION

SAFETY GUIDE

≈ THINK SAFETY AND WORK SAFELY!!!

PRECAUTION FOR SAFE WORKING

THIS MACHINE IS EQUIPPED WITH VARIOUS SAFETY FEATURES FOR GUARDING PERSONNEL AND THE MACHINE FROM UNFORESEEN ACCIDENTS.

HOWEVER THERE IS A POSSIBILITY THAT CARELESSNESS OR MISS-OPERATION OF MACHINE CAN CAUSE AN ACCIDENT.

WORKERS SHOULD NOT DEPEND ON THE SAFETY EQUIPMENT ALONE. THEY SHOULD FAMILIARIZE THEMSELVES WITH ALL OF THE ATTACHED INSTRUCTION MANUALS AND HAVE A SUFFICIENT UNDERSTANDING OF THE MACHINE BEFORE OPERATING AND MAINTAINING IT.

1-1 DEFINITION OF RISKS

THE DEGREE OF DANGER IS CLASSIFIED AS **DANGER, WARNING, CAUTION.**

DANGER

INDICATES AN IMMINENTLY HAZARDOUS SITUATION WHICH, IF NOT AVOIDED **WILL** RESULT IN DEATH OR SERIOUS INJURY.

WARNING

INDICATES A POTENTIALLY HAZARDOUS SITUATION WHICH, IF NOT AVOIDED, **COULD** RESULT IN DEATH OR SERIOUS INJURY.

CAUTION

INDICATES A POTENTIALLY HAZARDOUS SITUATION WHICH, IF NOT AVOIDED, **MAY** RESULT IN MINOR OR MODERATE INJURY. ALSO INDICATES A HAZARDOUS SITUATION WHICH MAY RESULT IN MACHINE DAMAGE.

CONTENTS DESCRIBED IN THE FOLLOWING PRECAUTIONS ARE ITEMS IN WHICH EXTREME CARE MUST BE TAKEN FOR THE MACHINE OPERATION AND MAINTENANCE.

IF THESE PRECAUTIONS ARE NOT OBSERVED, IT IS CONSIDERED THAT SERIOUS INJURY MAY BE CAUSED. THEREFORE, BE SURE TO HANDLE THE MACHINE ACCORDING TO THE INSTRUCTIONS.

1-2 BASIC PRECAUTIONS

DANGER SITUATIONS

1. **DO NOT** SOIL, DAMAGE OR REMOVE WARNING LABELS. IF THE LABEL BECOMES HARD TO READ OR IS LOST, PLACE AN ORDER TO **SANE KUEI** OR YOUR LOCAL AGENT.
2. **DO NOT** TOUCH THE SWITCHES WITH WET HANDS THIS CAN CAUSE AN ELECTRIC SHOCK.
3. SINCE THERE ARE HIGH VOLTAGE TERMINALS IN THE ELECTRIC CABINET(GENERATOR), TRANSFORMER, MOTOR, RELAY BOX, ETC. NEVER TOUCH THEM BECAUSE OF DANGER OF AN ELECTRIC SHOCK.
4. PREPARE A FIRE PREVENTION FACILITY IN THE WORKING AREA.
5. AVOID CONTACT VOLTAGES HIGHER THAN 25 VEFF.
6. THE CUSTOMERS APPOINTED ELECTRICIAN SHALL PERFORM THE ELECTRICAL CONNECTIONS TO THE POWER SUPPLY.

DAMAGED CABLE AND WIRE COVERINGS CAN CAUSE DANGER ELECTRIC SHOCK. CHECK THAT THE CABLE AND WIRE ARE SAFE.

8. WHEN LIFTING THE MACHINE, FOLLOW THE FOLLOWING PRECAUTIONS.
 - A) WHEN LIFTING THE MACHINE WITH THE FORK LIFT TRUCK, THE LICENSER OF THE FORK LIFT TRUCK SHALL PERFORM THE WORK.
 - B) CHECK THAT EACH PART IS FIXED BEFORE LIFTING THE MACHINE.
 - C) CHECK THAT UNNECESSARY MATTERS SUCH AS TOOLS, WASTE ,ETC., ARE NOT LEFT INSIDE OF THE MACHINE.
 - D) WHEN WORKING TOGETHER WITH TWO MEN OR MORE, COMMUNICATE WITH EACH OTHER AND TAKE EXTREME CARE.
9. ELECTRIC APPARATUS IS TO BE MAINTAINED BY THE ELECTRICAL SERVICE ENGINEERS

APPOINTED BY THE CUSTOMER.

10. MAINTENANCE WHICH IS IN DANGEROUS IF THE POWER IS TURNED ON, BE SURE TO TURN OFF THE POWER SUPPLY AND LOCK THE MAIN SWITCH OFF.

WARNING SITUATIONS

1. UNDERSTAND WHERE THE EMERGENCY STOP PUSH BUTTON IS POSITIONED SO THAT IT CAN ACCESSED AT ALL TIMES.
2. **DO NOT** REMOVE OR MODIFY ANY SAFETY EQUIPMENT.
3. BE SURE TO TURN OFF THE POWER SUPPLY BEFORE REPLACING A FUSE.
4. FAMILIARIZE YOURSELF WITH THE WORKING AREA SO AS NOT TO PLACE YOURSELF IN A DANGEROUS SITUATION.
5. IF WATER OR OIL DROPS ON FLOOR, IMMEDIATELY WIPE IT UP TO PREVENT SLIPPAGE.
6. CHECK THE SWITCH BEFORE OPERATING CORRECTLY.
7. **DO NOT** TOUCH THE SWITCH UNCONSCIOUSLY.
8. THE MACHINE AND ZNC DEVICE IS NOT TO BE EXPOSED BY A DIRECT SUNLIGHT. **DO NOT** PLACE A HEAT SOURCE NEAR THE MACHINE.
9. **DO NOT** PLACE THE MACHINE IN AN AREA LIKELY TO BE SUBJECT TO LARGE VIBRATIONS.
10. PLACE THE MACHINE ON A SUFFICIENTLY STRONG, FLAT AND LEVEL SURFACE.
11. DO NOT PLACE THE MACHINE WHERE DUST OR MIST CAN BE SUCKED INTO THE MACHINES COOLING FANS.
12. AN EXCESSIVE VOLTAGE DROP BY THE INSUFFICIENT CAPACITY OF THE SHOP POWER SUPPLY CAN CAUSE AN OPERATIONAL ERROR OF THE ZNC DEVICE.
13. GROUND THE MACHINE TO THE PE TERMINAL INSIDE THE ELECTRIC CABINET (GENERATOR) TO

PREVENT ELECTRICAL LEAKAGE AND ELECTRICAL NOISE. THUS, USE SEPARATE EARTH LINES TO EQUIPMENT SUCH AS ELECTRIC WELDERS, ETC.

14. ARRANGE THE MAINTENANCE SCHEDULE AND WORKING ENVIRONMENT, AND ALSO, WIPE OIL AND WATER TO MAKE THE WORK AREA SAFE.
15. UNNECESSARY PARTS AND WASTE OIL ARE TO BE ABANDONED BY THE INSTRUCTION OF SUPERVISOR.
16. REPLACE OR REFILL FIRE EXTINGUISHERS AS OUR DIRECTION OF PAGE .
17. FOLLOW THE OPPOSITE PROCEDURES OF ASSEMBLY TO DISMANTLE THE MACHINE.
18. DO NOT USE THE SAME ELECTRIC POWER SUPPLY WITH OTHER MACHINES, E.G. ELECTRIC WELDERS, MILLING MACHINES, ETC.

CAUTION SITUATIONS

1. LUBRICATION OIL, DIELECTRIC, ETC., USED ARE TO BE TO SPECIFICATION.
2. **DO NOT** HIT ZNC DEVICE, OPERATION PANEL, POWER CONTROL PANEL, ETC.
3. **DO NOT** DROP WATER OR DUST ONTO ZNC DEVICE, OPERATION PANEL, ELECTRIC CABINET (GENERATOR), ETC. BE SURE TO CLOSE DOORS AND COVERS, ETC.
4. THE FUSE RATING IS CORRECT.
REPLACE WITH A NEW ONE AS NECESSARY.
5. AVOID LEAKAGE OF THE WORKING FLUID.
6. HANDLE THE DISPOSAL OF FILTER AND WORKING FLUID ACCORDING TO LOCAL REGULATIONS.
7. THE PACKAGES (CRATES) MUST NOT BE DROPPED OR TIPPED.
8. THE EARTH LINE USED IS THE SAME SIZE AS INPUT LINE AND AS SHORT AS POSSIBLE.
9. IF RUST PREVENTIVE IS COATED ON SLIDE WAYS, THOROUGHLY REMOVE IT.
10. THE OPERATION AFTER MAINTENANCE IS TO BE CHECKED PERSON RESPONSIBLE FOR MAINTENANCE.
11. BE SURE TO REFER TO THE SPECIFICATIONS OF MACHINE, DIELECTRIC, LUBRICATION OIL, AND ETC., TO CARRY OUT THE MAINTENANCE WORK.

1-3 ENVIRONMENTAL CONDITIONS

- A. AMBIENT AIR TEMPERATURE: +5°C. TO + 40°C.
- B. HUMIDITY : 30% TO 95%.

1-4 INSTRUCTIONS RELATING TO HEALTH

- A. ONLY THE SKILLED OR TRAINED PERSONS CAN OPERATE THE MACHINE.
- B. MAINTENANCE AREA SHOULD BE FREE FROM OBSTRUCTIONS AND GREASY DIRT.
- C. ENSURE THE WORKSHOP HAS EFFECTIVE LOCAL AND GENERAL VENTILATION TO AVOID INHALING THE EROSION FUMES AND THE DIELECTRIC VAPOR.
- D. THE CONTACT BETWEEN SKIN AND DIELECTRIC SHOULD BE KEPT TO A MINIMUM.
- E. CONSULT AND COMPLY WITH THE RELEVANT PRODUCT INFORMATION.
- F. WEAR A PROTECTIVE MASK TO AVOID THE DUST OR EXHAUST GAS.

1-5 FIRE PREVENTION

THE ROOM EQUIPPED WITH SPARK EROSION MACHINE IS CONSIDERED AS HAVING A FIRE HAZARD WHILE THE MACHINE IS OPERATED WITH FLAMMABLE DIELECTRIC.

- A. THE WORKSHOPS THAT MAY HAVE A FIRE OR EXPLOSION HAZARD SHOULD NOT HAVE THE ELECTRICAL INSTALLATION.
- B. THE PRESENCE OF NAKED FLAMES AND SMOKING IS TO BE PROHIBITED IN THE VICINITY OF THE SPARK EROSION SYSTEM.
- C. THE WORKSHOP MUST BE PROVIDED WITH ADEQUATE OF FIRE EXTINGUISHERS.
- D. THE INFORMATION MUST BE PROVIDED BY THE REVENANT SUPPLIER FOR THE STORAGE OF DIELECTRIC.
- E. THE POSITION OF FIRE EXTINGUISHER, WE SUGGEST OUR EDM USER SHOULD POSITION 2 FIRE EXTINGUISHERS AS FIG. 1-5 POSITION.

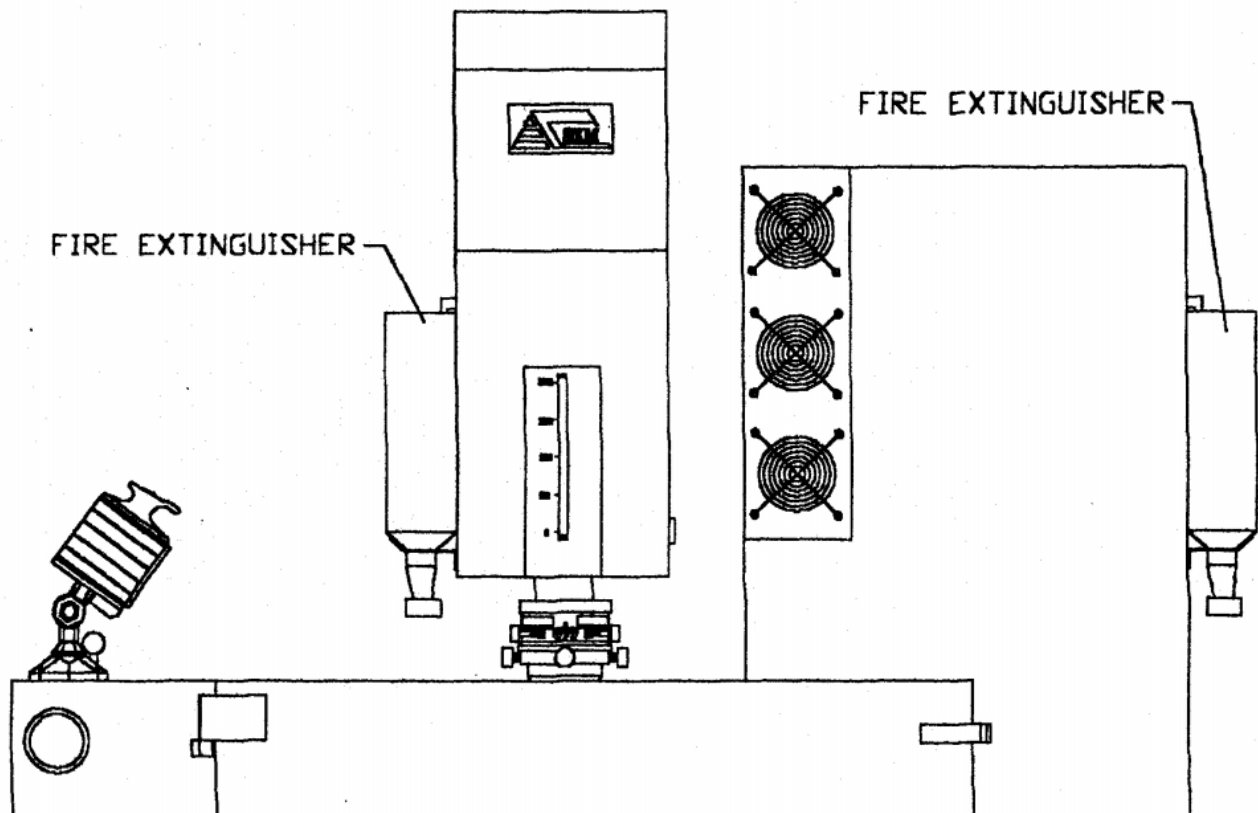

FIG. 1-5

1-6 INSPECTION

A. BEFORE POWER ON

PLEASE MAKE SURE OF THE FOLLOWING:

1. THE POWER SOURCE OF THE MACHINE.
2. OUTSIDE GROUNDING IS INSTALLED.
3. THE ELECTRICAL CABINET IS WELL CLOSED.
4. THE LUBRICATION OIL IS FULL IN THE LUBRICATION POT.
5. THE WORKING FLUID IS FILLED IN ACCORDING TO INDICATION LEVEL.
6. THE PROTECTING GUARD AND SAFETY DOOR ARE WELL CLOSED.
7. ALL PRESSURE INDICATOR IS AT "0" POSITION.
8. THE PIPES OR HOSES HAVE NO BREAKAGE OR LOOSENESS.

B. AFTER POWER ON

PLEASE MAKE SURE OF THE FOLLOWING AND REFER TO THE OPERATION PROCEDURE OF ALL BUTTON FUNCTIONS IN THE PANEL CONTROL OPERATING MANUAL:

1. THERE IS NO ALARM MESSAGE.
2. THE OUTPUT CABLE IS NORMAL.
3. ALL THE MOVING COMPONENTS FUNCTION NORMALLY.
4. THE WORKING FLUID MAIN PRESSURE IS INDICATED AS 1.5 KGB/C.
5. TURN OFF THE LIGHT WHEN THE USER IS NOT AROUND WORK PLACE.

C. BEFORE TESTING

1. MAKE SURE THE SAFETY SYSTEM WHICH INCLUDE FLUID TEMPERATURE LIMITING SYSTEM, THE DETECTORS FOR THE SURFACE-LEVEL OF THE WORKING-FLUID, LIGHT-FIRE SENSOR SYSTEM ARE NORMAL.
2. MAKE SURE THAT THE ELECTRODE HOLDER IS WELL LOCKED.
3. MAKE SURE THE WORKPIECE IS WELL LOCKED ON THE TABLE.
4. MAKE SURE THE FLUID IN THE WORK TANK IS ABOVE 50 MM OF THE TOP OF WORK PIECE.
5. MAKE SURE THE PUMP IS FILLED WITH WORKING FLUID.

1-7 REPLACEMENT & SERVICING INTERVALS

THE SPECIFICATION FOR ROUGHING

A. ROUGHING

Product	Max. removal	Min. wear	Viscosity (20/ 68)	Density (20/ 68)	Flash point (:)	Aromatic contents (%)
AVIA IMA 126	●		5.8	0.82	126/258.8	1
BP 250	●	●	6	0.81	125/257	2
ESSO DE - FLUID	●	●	7.37	0.82	124/255.2	0.65
SHELL 5585	●		6.2	0.81	106/222.8	0.2

THE SPECIFICATION FOR FINISHING

B. FINISHING

Product	Max. removal	Min. wear	Viscosity (20/ 68)	Density (20/ 68)	Flash point (:)	Aromatic contents (%)
ESSO SOMENTOR 31	●	●	2	0.8	78/172.4	0.6
FLUXELF 1 FUCHS	●	●	2.53	0.79	90/194	1
RATAK FEL ZELLER U. GMEHLIN MULTIC. FU LIECHT		●	2	0.75	72/161.6	0
			1.9	0.75	80/176	0.1

FIRE PREVENTION FACILITY

THE FIRE EXTINGUISHER, SOLKAFLAM 123, IS DESIGNED TO LAST THE LIFE TIME OF THE EXTINGUISHER. THE USER MUST REFILL THE FORMULA, I F NECESSARY. (THE SUGGESTED BRAND OF REFILLED FORMULA IS SOLKAFAM 123)

SPECIFICATION OF FIRE EXTINGUISHER

PHYSICAL DATE / BRAND	SOLKAFLAM 123
CHEMICAL FORMULA	CHC12-CF3
MOLECULAR WEIGHT	152.9
BOILING POINT AT 1.013 BAR (°C)	27.6
DENSITY OF THE LIQUID AT 20°C (kg / dm)	1.48
VAPOR PRESSURE AT 20°C (BAR)	0.76
VAPOR PRESSURE AT 50°C (BAR)	2.14
VAPOR PRESSURE AT 80°C (BAR)	4.90
CRITICAL TEMPERATURE (°C)	184
CRITICAL PRESSURE (BAR)	36.7
ODP	0.02
GWP	0.02
ABOUT TOXICITY (LC50 RAT, 4H, PPM)	32000
EXTINGUISHING CONON, HEPTANE (VOL%)	7.1

REPLACEMENT METHOD

WE SUGGEST THE REFILL OR REPLACEMENT SHOULD BE PERFORMED BY TRAINED PERSON OR QUALIFIED SUPPLIER AND OBSERVES LOCAL REQUIREMENT. **DO NOT SPILL AND DRIP THE WORKING FLUID INTO THE GROUND.**

1. THE SUGGESTED REPLACEMENT METHOD IS USING VACUUM CLEANER(THE TYPE FOR LIQUID).
2. PLEASE CONSULT WITH THE AGENT OR **SKM** FOR REPLACEMENT.

NOTE: AS SOON AS CONTACT WITH THE SPILLED FLUID, USE WATER TO CLEAN THE CONTACTED PART FIRST.

WORKING FLUID

THE PURPOSE OF DIELECTRIC ARE AS FOLLOWING:

1. INSULATION
2. COOLING
3. FLUSHING

TO SATISFY THOSE PURPOSES, PLEASE CHOOSE THE DIELECTRIC ACCORDING TO THE RECOMMENDED SPECIFICATIONS BELOW OR EQUIVALENT BRAND. (THE FLASH POINT OF WORKING FLUID MUST BE OVER 60° C.

A. UNIVERSAL USE

Product	Max. removal	Min. wear	Viscosity (20/ 68)	Density (20/ 68)	Flash point (:)	Aromatic contents (%)
AGIP Lamium 14	●	●	3.32	0.77	109/228.2	0.5
ARALUX MF	●	●	3.60	0.79	125/257	0
AVIA IMA 82	●	●	3.20	0.78	82/179.6	0.3
BP 200T	●	●	2.90	0.76	104/219.2	0
CASTROL SE FLUID 180	●	●	3.25	0.81	106/222.8	0.9
CMT COLL 7-22	●	●	3.50	0.76	112/233.6	0
COMMONWEA LTH OIL EDM 244	●		3.70	0.75	117/242.6	<1
ESSO DE-FLUID 38	●	●	3.27	0.76	117/242.6	0.01
FUCHS RATARK FEL-S		●	3.00	0.78	75/167	0
MILL SOREPIM	●	●	3.48	0.79	88/190.4	0.3

SERVICING INTERVALS

Regularly or when necessary	Weekly	Monthly	Half - year or 1000 hr	Yearly or 2000 hr	Description
●					General upkeep of machine
●					Drain and clean out the clean tank
●					Drain and clean out the sludge tank
●					Change cartridge filters
●					Check all safety devices function
●					Check the fire prevention system
●					Check the extraction equipment
●					Please always pull the handle-bar of lubrication pot before starting the machine
●					Check the workpiece and tool electrode clamped before start the machine
●					Change the working fluid if it is dirty
	●				Clean oil wiper on sleeve
	●				Clean the generator filter
		●			Grease clamping chuck
		●			Clean work tank float switches
		●			Check the pressure gauge and sensor of fire extinguisher
		●			Clean work tank seal
			●		Clean outlet valves in flushing distribution block
				●	Replenish centralized lubrication system

--GENERAL MACHINE UPKEEP OF SANE KUEI EDM MACHINE:

YOUR MACHINE MUST BE REGULARLY CLEANED AND MAINTAINED. CLEANING FREQUENCY IS MAINLY DEPENDENT ON TYPE OF WORK AND ENVIRONMENT. PLEASE REFER TO THE SERVICING INTERVALS FOR MAINTENANCE .

1-8 WARNING LABELS

WARNING LABELS :

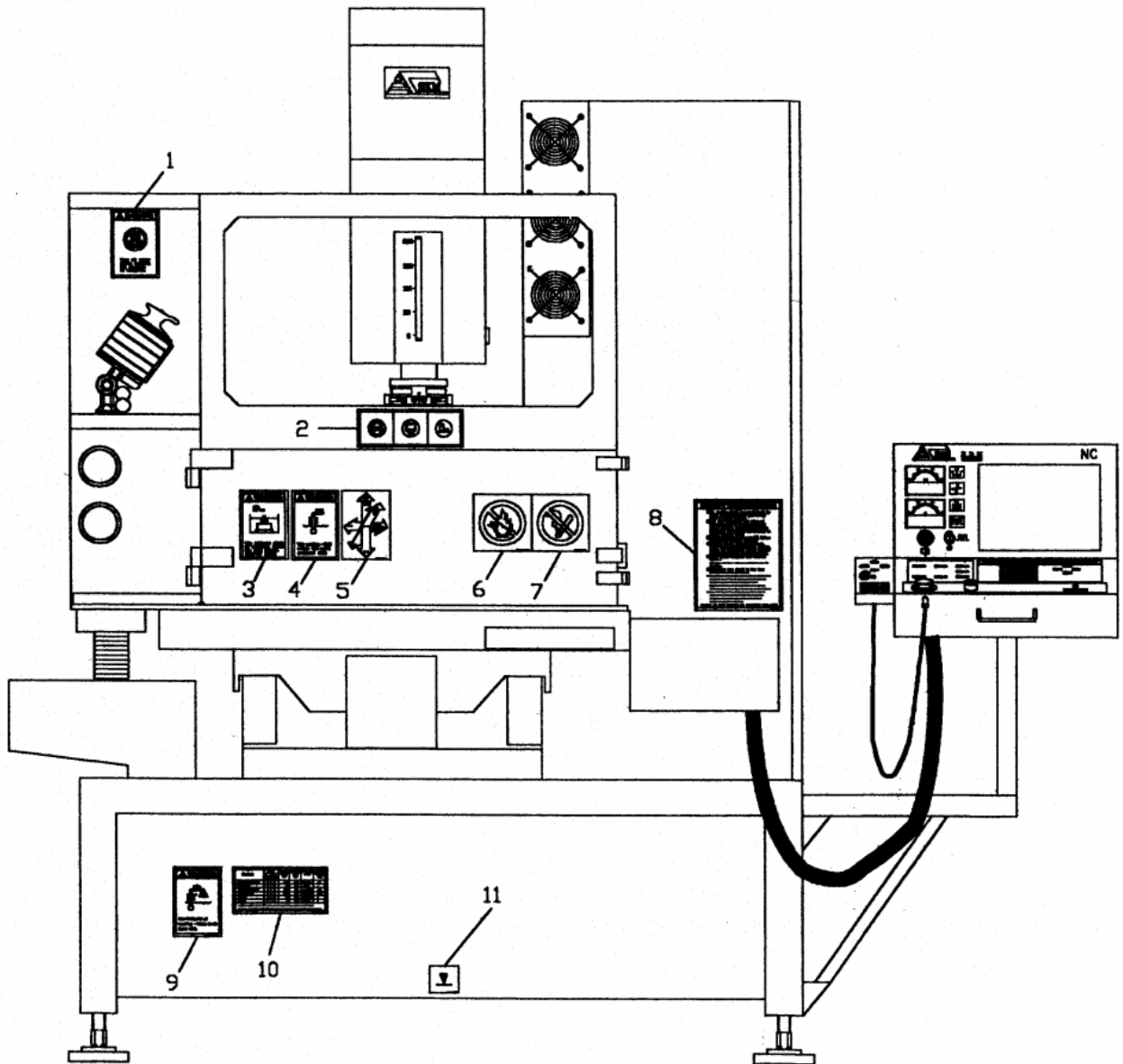

WARNING LABELS :

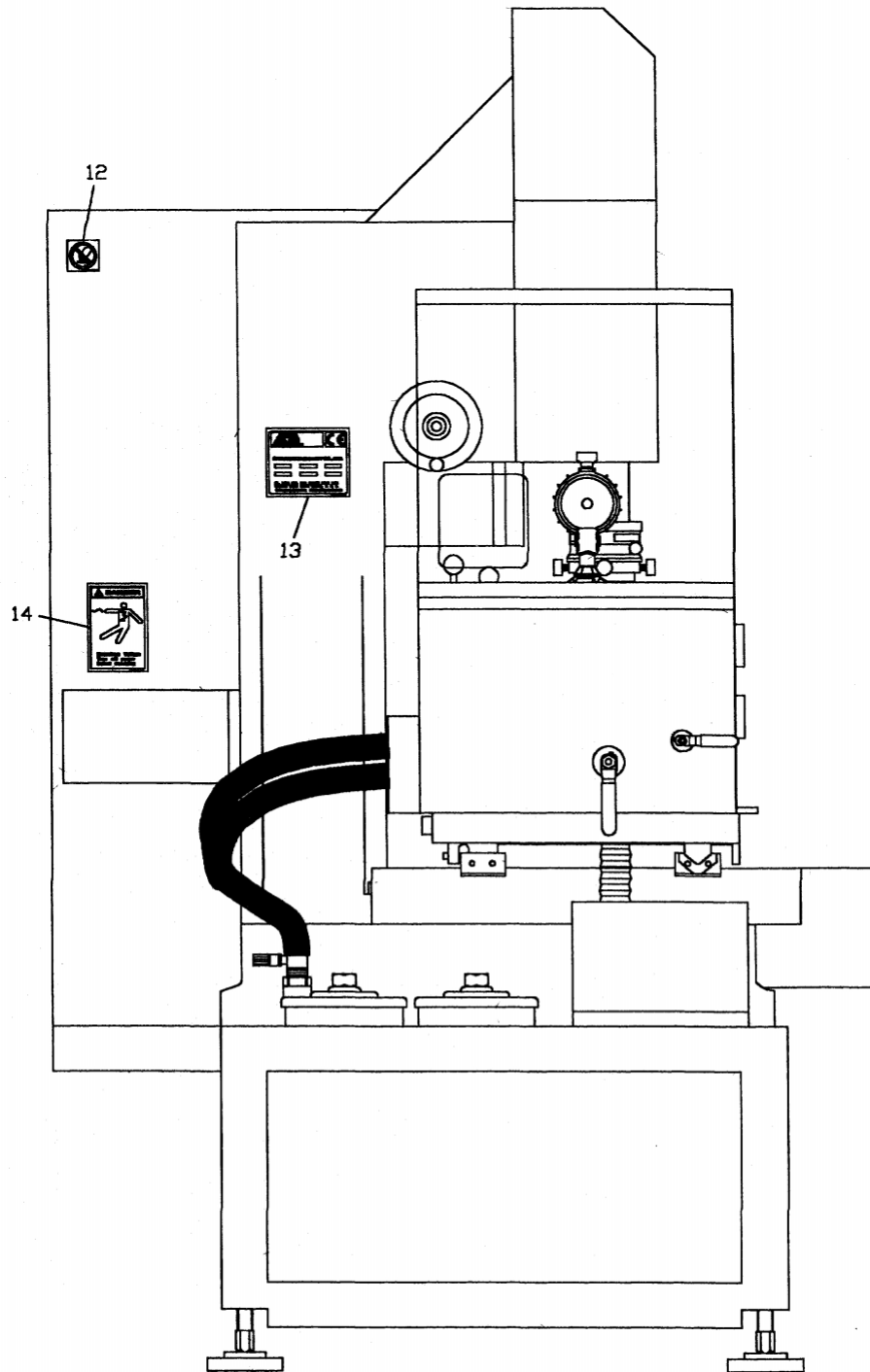

WARNING LABELS :

1.

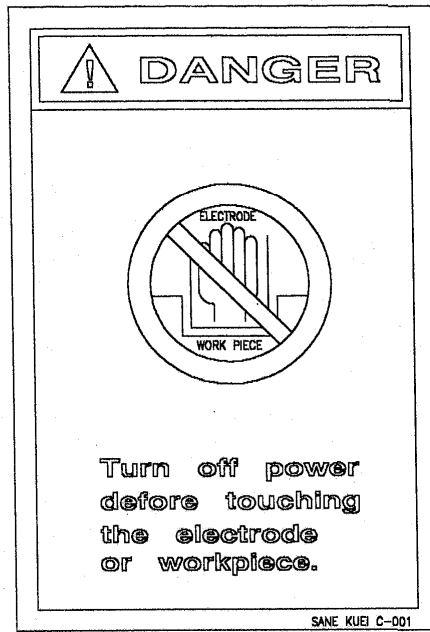

2.

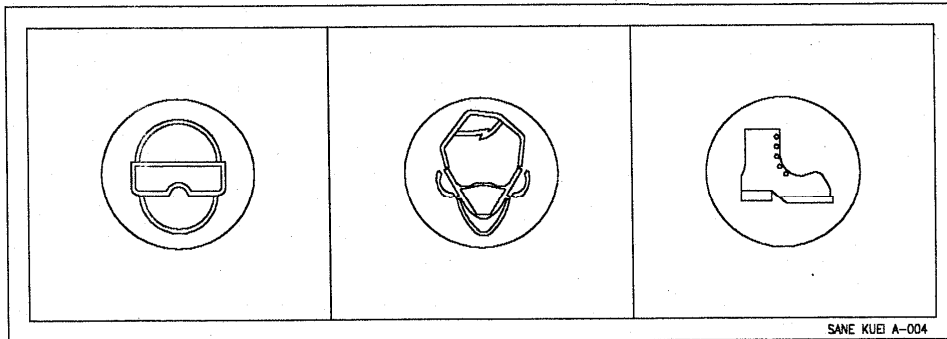

WARNING LABELS :

3.

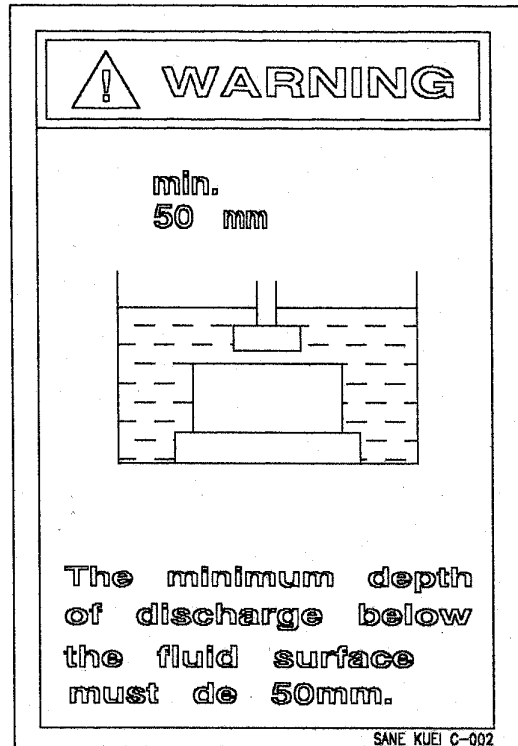

4.

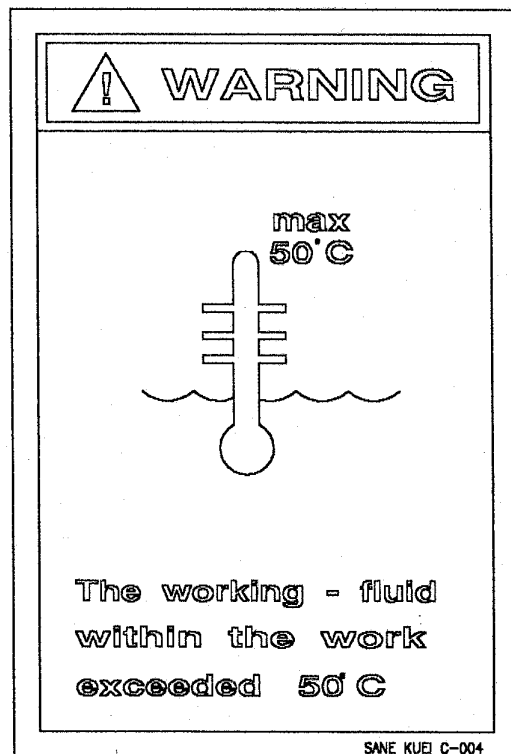

WARNING LABELS :

5.

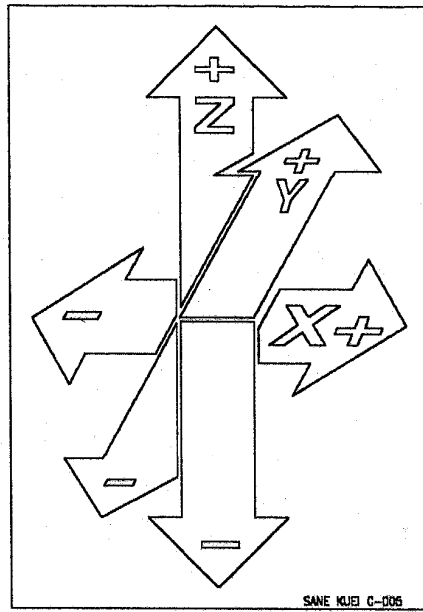

6.

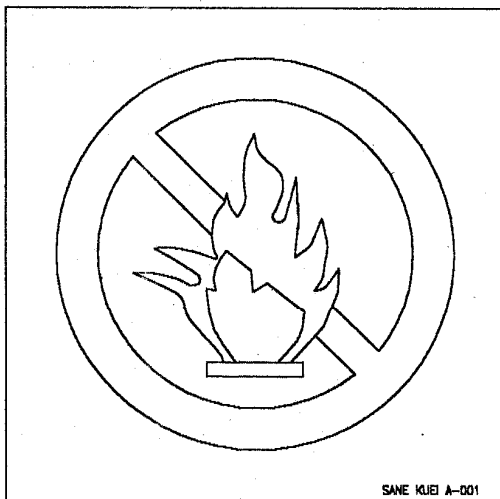

7.

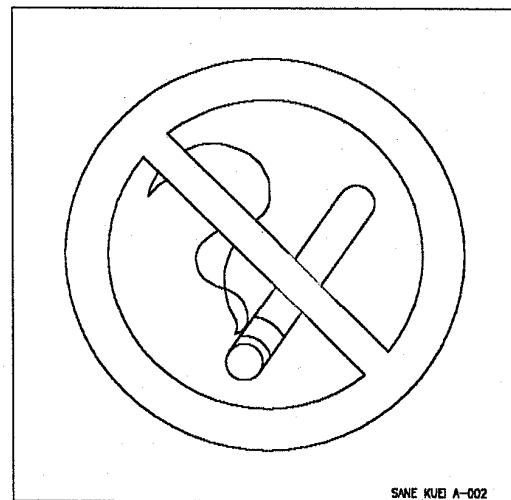

8.



SAFETY INSTRUCTIONS

- 1 This machine should only be operated by properly trained persons.
- 2 The operator must read, understand and follow all instructions and warnings.
- 3 This machine should not be operated by anyone fitted with a pacemaker.
- 4 Always check the sparking power is off before touching the workpiece or electrode.
- 5 Operators should wear safety glasses, safety shoes and should remove rings, watches, jewellery and loose fitting clothing for their own protection while operating the machine.
- 6 Always clamp the workpiece and electrode securely.
- 7 Maintenance area should be kept free from obstructions, grease and dirt.
- 8 Service or installation of this machine must be performed by qualified personnel only. Follow procedures described in the operating manuals. Turn off and lock out power at the main electrical panel before servicing.
- 9 This machine should be situated at least 3 Metres from other equipment.
- 10 This machine may interfere with radio broadcast equipment.
- 11 If you have any problems about the safe operation of the machine, refer to your supervisor immediately or consult **ANOTRONIC LIMITED.**

PLEASE DO NOT REMOVE OR DISFIGURE THIS SIGN

© ANOTRONIC LTD. 1996

WARNING LABELS :

9.

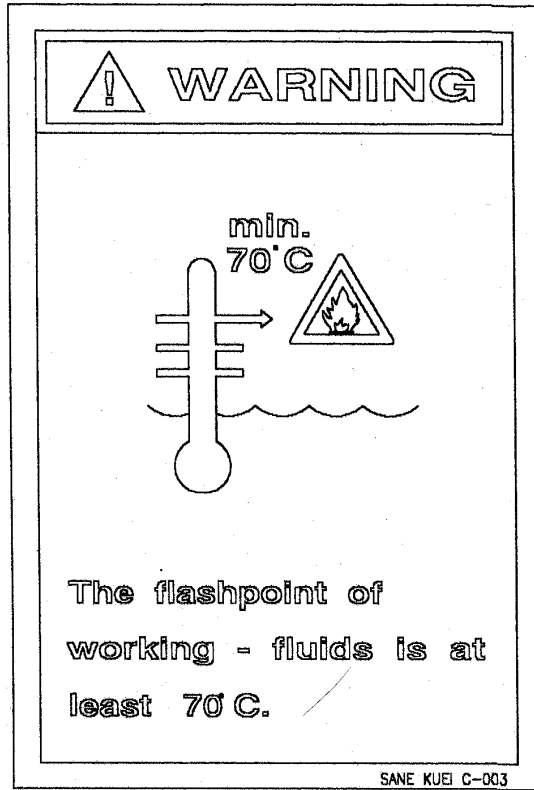

10.

Product	Use		Viscosity (20°C/ 68°F)	density (20°C/ 68°F)	Flash point (°C:°F)	Aromatic contents (%)
	Max. removal	Min. wear				
AGIP Lamium 14	●	●	3.32	0.77	109/228.2	0.5
ARALUXMF	●	●	3.6	0.79	125/257	0
ESSO DE-FLUID 38	●	●	3.27	0.76	117/242.6	0.01
ESSO DE-FLUID	●	●	7.37	0.82	124/255.2	0.65
BP 200T	●	●	2.9	0.76	104/219.2	0
BP 250	●	●	6	0.81	125/257	2

YOU CAN USE THE OTHER SAME LEVEL DIELECTRIC OIL BESIDES ABOVE RECOMMENDATION LIST , BUT THE FLASH POINT MUST BE OVER THANK 70°C.

SANE KUEI E-004

WARNING LABELS :

11.

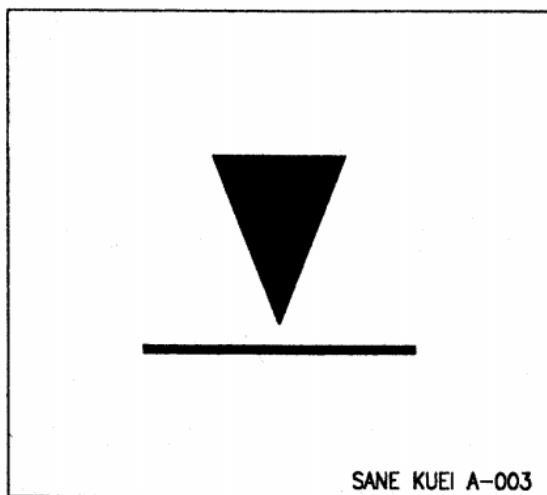



12.



MARKING :

13

	三貴	
三貴機械有限公司		
SANE KUEI MACHINERY CO., LTD.		
機械型式 MODEL NO.	週率 FREQ	日期 DATE
<input type="text"/>	<input type="text"/>	<input type="text"/>
機械號碼 MACHINE NO.	電壓 VOLT	機械重量 NW kgs
<input type="text"/>	<input type="text"/>	<input type="text"/>
台北縣新莊市化成路 229 巷 21 號 21, LANE 229, HUA CHENG ROAD HSIN CHUANG TAIPEI HSIEN TAIWAN, R. O. C. TEL : (02) 2765141 FAX : (02) 2765140		

WARNING LABELS :

14

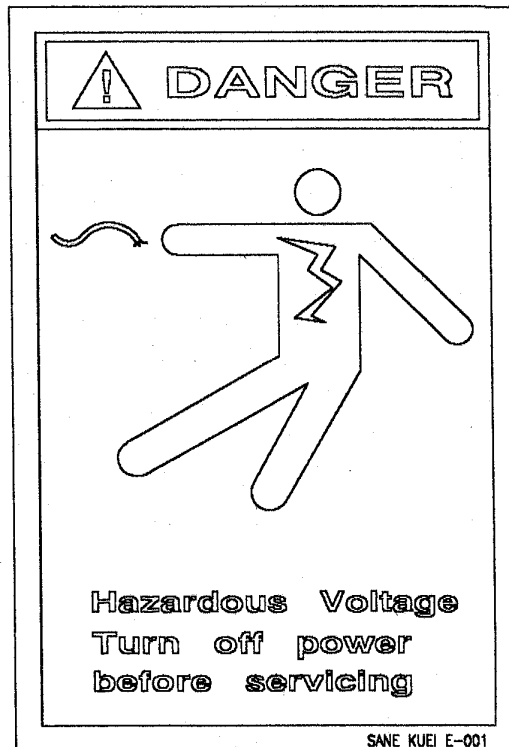

1-9 CONFIGURATION OF MACHINE AND OPERATION POSITION

CONFIGURATION OF MACHINE AND OPERATION POSITION :

NOTE :

T50 T60 ZNC MODELS OF SKM (D) ONLY DIMENSION IS DIFFERENT.

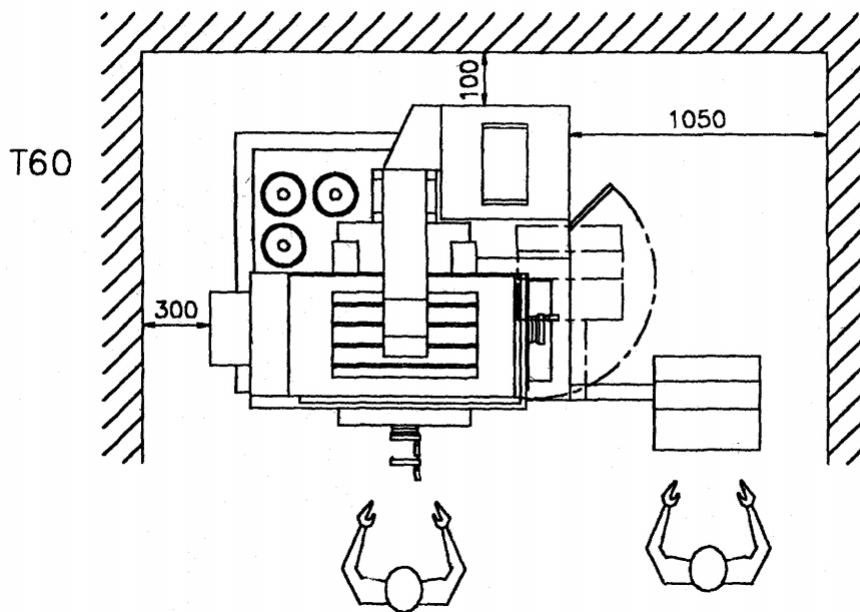
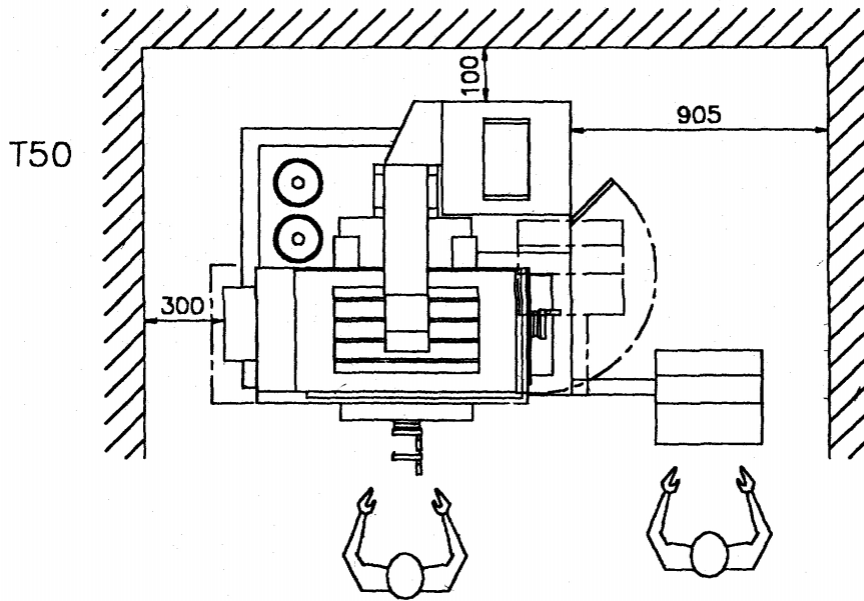

CONFIGURATION OF T50/T60 MACHINE

NOTE :

K50 K60 NC MODELS OF SKM (D) ONLY DIMENSION IS DIFFERENT.

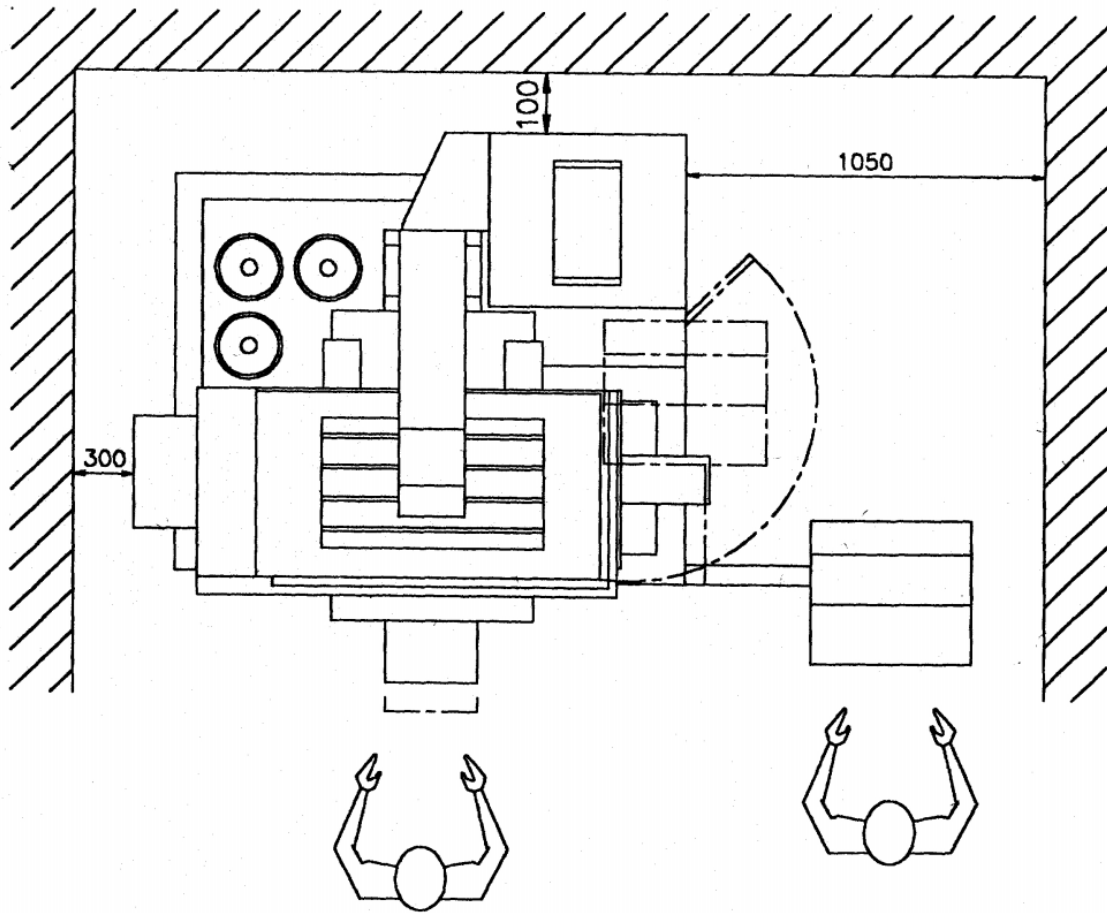

CONFIGURATION OF K60 MACHINE



Anotronic-SKM EDMs
Manual, ZNC, CNC



Anotronic-Ocean
EDM Drilling Machines
Manual, ZNC, CNC



CNC Wire EDM Sub-Contract
On The Latest Technology
Machines



Anotronic Electrochemical
Deburring Machines (ECD)



CNC CMM inspection



Multi axis CNC Turning



Fully Automated 5axis cnc Milling

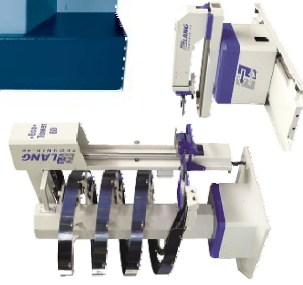

5axis cnc Milling

Perhaps You Did Not Realise How Much **ANOTRONIC** Has To Offer!

- Full High capacity Machine Shop including fully Automated 5axis cnc Milling, Multi axis CNC Turning, Grinding etc.
- Laser Part marking
- CNC CMM inspection
- Sale of Standard Electric Discharge Machines (Manual, ZNC & CNC) to take components up to 2500mm x 1200mm x 700mm.
- Design, Manufacture & Sale of Electrochemical Deburring Machines (ECM)
- Comprehensive After Sales Service.
- Design, Manufacture & Sales of EDM & ECM Tooling and Electrodes.
- Multi axis CNC EDM & ECM Sub-Contract Service.
- ECM Sub-Contract Service.
- Wire EDM Sub-Contract Service with cutting areas up to 500mm x 320mm x 420mm HIGH.
- EDM small hole drilling Machines and Sub-Contract Service.
- EDM/ECM Consultancy Service.



ANOTRONIC LTD.

Unit 3, Hollingdon Depot, Stewkley Road, Soulbury,

Nr. Leighton Buzzard, Beds., LU7 0DF. England.

Telephone +44 (01525) 270261 Fax +44 (01525) 270235

E-Mail sales@anotronic.com Internet <http://www.anotronic.com>

Anotronic Ltd is a company registered in England & Wales with company number 1658055
Registered at the above address. • VAT number 382-1697-32 • © copyright Anotronic Ltd. 1999-2013